

OWNER'S MANUAL

MEDIUM DUTY JACK SHAFT OPERATOR

MODEL NO.

MDJ, MDJH, MDJB, MDJBH

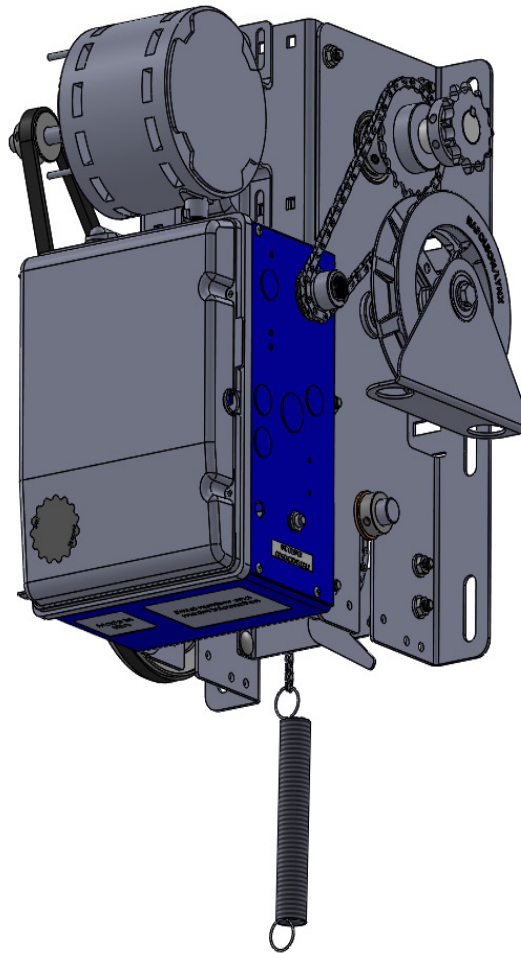

Napoleon/Lynx™

**READ AND FOLLOW ALL INSTALLATION INSTRUCTIONS
SAVE THESE INSTRUCTIONS**

NOT FOR RESIDENTIAL USE

This unit is intended for limited duty applications not to exceed 12 cycles of opening and closing per hour.

100TA01T - CDJ MANUAL - 02

SPECIFICATIONS

MOTOR

TYPE:	Intermittent duty
HP:	1/2 HP
SPEED:	1500 RPM
VOLTAGE:	115V 1 Phase 60Hz
CURRENT:	See motor nameplate

ELECTRICAL

TRANSFORMER:	24VAC
CONTROL STATION:	3-button station OPEN/CLOSE/STOP
WIRING TYPE:	B2 (Standard, when powered)
	C2 (When photoeyes are blocked or not present)
LIMIT ADJUST:	Linear driven, fully adjustable screw type cams. Adjustable to 24 feet.

MECHANICAL

DRIVE REDUCTION:	Primary: Heavy duty (4L) V-Belt
	Secondary: #41 chain/sprocket
	Output: #41 chain
OUTPUT SHAFT SPEED:	27 RPM
DOOR SPEED:	Approx. 5.4" per sec. depending on door.
BRAKE (Optional):	Solenoid actuated drum brake
BEARINGS/BUSHINGS:	Ball bearing with hardened races & Oil Impregnated Bushings
HAND CHAIN WHEEL(optional):	Left or Right

SAFETY

DISCONNECT:	All Models: Floor level disconnect for manual door operation.
REVERSING EDGE:	(Optional) Electric or pneumatic sensing device attached to the bottom edge of door. A REVERSING EDGE IS STRONGLY RECOMMENDED FOR ALL COMMERCIAL OPERATOR INSTALLATIONS. REQUIRED WHEN THE 3 BUTTON CONTROL STATION IS OUT OF SIGHT OF DOOR OR ANY OTHER CONTROL (AUTOMATIC OR MANUAL) IS USED.

DIMENSIONS & WEIGHT

HANGING WEIGHT:	65-75 LBS
SHIPPING WEIGHT:	85-95 LBS

SAFETY

WARNING



Improperly operating or an unbalanced door could cause SERIOUS INJURY or DEATH. See Door

Manufacturer's Owner's Manual. Have trained door systems technicians make repairs to cables, spring assemblies, and other hardware.

WARNING



To prevent SERIOUS INJURY or DEATH:

- DO NOT connect electric power until instructed to do so.



- ALWAYS call a trained professional door serviceman if door binds, sticks or is out of balance. An unbalanced door may not reverse when required.

- NEVER try to loosen, move or adjust doors, door springs, cables, pulleys, brackets or their hardware, ALL of which are under EXTREME tension and can cause SERIOUS PERSONAL INJURY.

- DISABLE ALL locks and remove ALL ropes connected to door BEFORE installing and operating door operator to avoid entanglement.

PREPARATION

It is imperative that the wall or mounting surface provide adequate support for the operator.

The surface must:

- a. Be rigid to prevent play between operator and door shaft. (Spreader bars will also be of aid when the door shaft is not supported properly by an end bearing)
- b. Provide a level base
- c. Permit the operator to be fastened securely and with the drive shaft parallel to the door shaft.

The safety and wear of the operator will be adversely effected if any of the above requirements are not met.

For metal buildings, fasten 2" x 2" x 3/16" (or larger) angle iron frames to the building purlins. Retain 7-1/2" between frames (Figure 1).

All MDJ, MDJH, MDJB, and MDJBH operators have dual output shafts and may be mounted on either the right (standard) or the left side of the door. Install the sprocket on the side desired and insert the key. Be sure to tighten Both set screws securely.

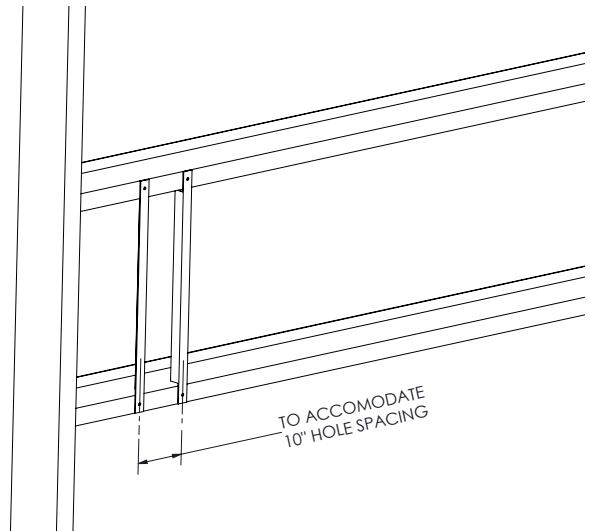

IMPORTANT NOTE: To aid installation, see page 16 (Shop Drawing) for mounting consideration.

INSTALLATION

WARNING



Moving parts on the operator could cause possible **SERIOUS INJURY**. Install the operator at least 8 feet above the floor to keep people away from the moving parts.

IMPORTANT NOTE: Before your operator is installed, be sure the door has been properly aligned, balanced, and is working smoothly.

1. Wall Mount:

- A The operator should generally be installed below the door shaft, and as close to the door as possible. The optimum distance between the door shaft and operator drive shaft is between 12-1/2" - 15-1/2" (Figure 2)
- B Place the door sprocket on the door shaft. Do not insert the key at this time.
- C Ensure the drive sprocket on the operator is on the appropriate side.
- D Wrap the drive chain around the door sprocket and join the roller chains end together with master link. (NOTE: The chain may need to be made shorter depending on the operator mounting position)
- E Raise the operator to approximate mounting position and position the chain over the operator drive sprocket.
- F Raise or lower the operator until the chain is taut (not tight). Make sure the operator output shaft is parallel to the door shaft and secure the operator in position.
- G Align the door sprocket to the operator drive sprocket (Figure 3), insert the key, and secure with BOTH set screws.

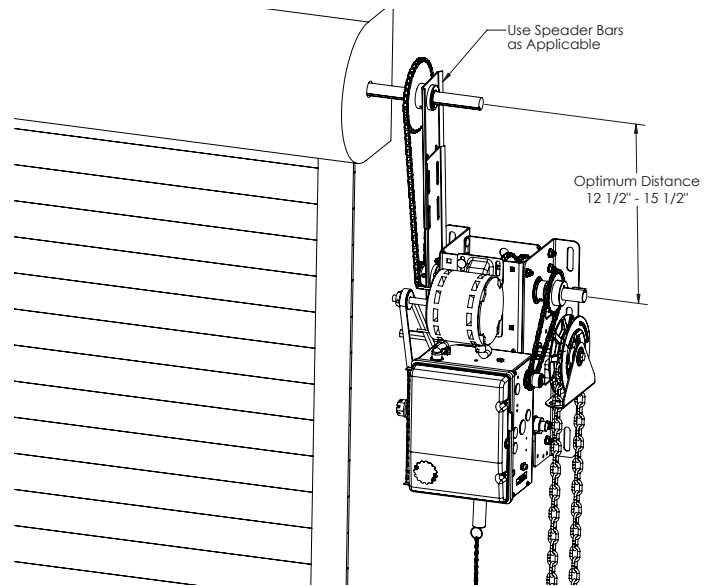

FIGURE 2

2. Install Hand Chain (Models MDJH and MDJBH only):

Thread hand chain around hand chain wheel ensuring that it passes through both openings in the hand chain guide. Remove enough links that so that the loop hangs approximately two feet above the floor.

3. **Mount Manual Disconnect/Chain Keeper:** Using suitable hardware, mount the manual disconnect directly beneath the operator approximately four (4) feet above the floor. Install the sash chain on the spring that hangs from the operator and thread through the sash chain lock (Figure 4, page 5). Pulling down on the sash chain pull ring, should disengage the motor from door assembly allowing for manual operation.

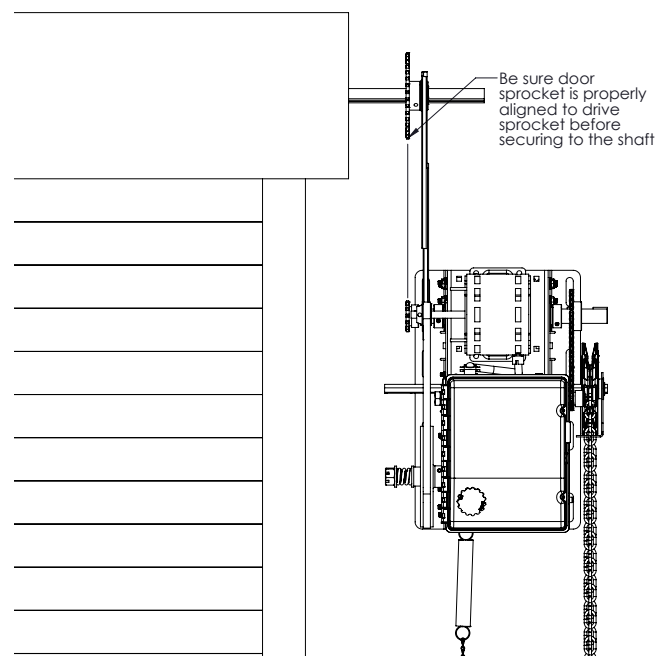

FIGURE 3

MANUAL OPERATION

⚠ WARNING



Moving chain could cause possible **SERIOUS INJURY. DISCONNECT electric power to the operator **BEFORE** manually operating your door**



⚠ WARNING



Broken Spring(s) may cause the door to fall rapidly, causing **SEVERE INJURY or **DEATH**. If possible only use the manual release when the door is closed, otherwise use caution when using the release while the door is open.**

This operator has provisions for manually operating the door in case of emergency or power failure.

1. Pull the sash chain down until it is tight. Then lock it into the sash chain lock in the wall bracket (Figure 4). This will disengage the motor. It will also engage the hoist mechanism if present.
2. Operate the door manually as desired.
3. To return to electrical operation, release the sash chain from the lock (Figure 4).

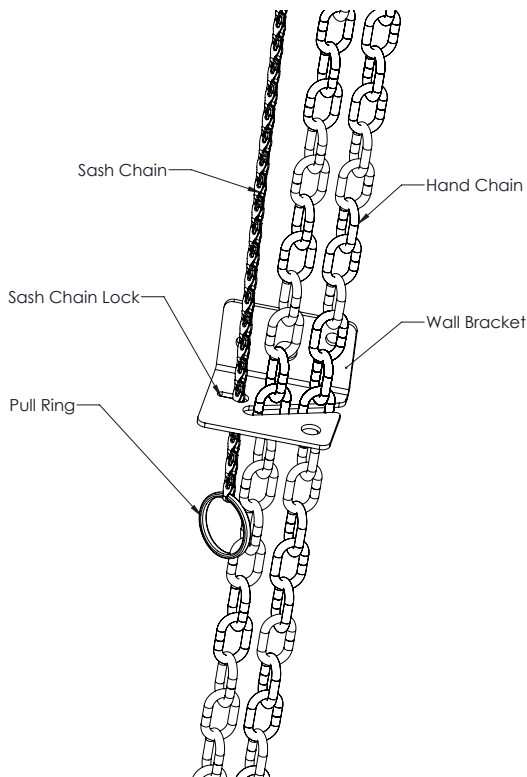

FIGURE 4

ENTRAPMENT PROTECTION ACCESSORIES (OPTIONAL)

SENSING EDGES

All types of sensing edges with an isolated normally open (N.O.) output are compatible with your operator. This includes pneumatic and electric edges. If your door does not have a bottom sensing edge and you wish to purchase one, contact the supplier of your operator.

If not pre-installed by the door manufacturer, mount the sensing edge on the door according to the instructions provided with the edge. The sensing edge may be electrically connected by either coiled cord or take-up reel.

IMPORTANT NOTES:

- Proceed with Limit Switch adjustments before making any sensing edge wiring connections to operator as described below.
- Electrician must hardwire the junction box to the operator electrical box in accordance with local codes.

! WARNING



To reduce risk of **SEVERE INJURY or DEATH**, ALWAYS install reversing sensors when the 3-button control station is out of sight of door or ANY other control (automatic or manual) is used. Reversing devices are recommended for all installations.

WIRING: For wiring of your sensing device to the operator, refer to the wiring diagram supplied with your operator. See field connection terminals identified as Safety Device.

TAKE-UP REEL: Take-up reel should be installed 12" above the top of the door.

COIL CORD: Connect operator end of coil cord to junction box (not supplied) fastened to the wall approximately halfway up the door opening.

LIMIT SWITCH ADJUSTMENT

! WARNING



To avoid **SERIOUS PERSONAL INJURY or DEATH** from **electrocution**, disconnect electric power **BEFORE** manually moving limit nuts.

IMPORTANT NOTE: Make sure the limit nuts are positioned between the limit switch actuators before proceeding with adjustments.

- To adjust limit nuts depress retaining plate to allow nut to spin freely. After adjustment, release plate and ensure it seats fully in slots of both nuts.
- To increase door travel, spin nut away from actuator. To decrease door travel, spin limit nut toward actuator.
- Adjust open limit nut so that door will stop in open position with the bottom of the door even with top of door opening.
- Repeat Steps 1 and 2 for close cycle. Adjust close limit nut so that actuator is engaged as door fully seats at the floor.

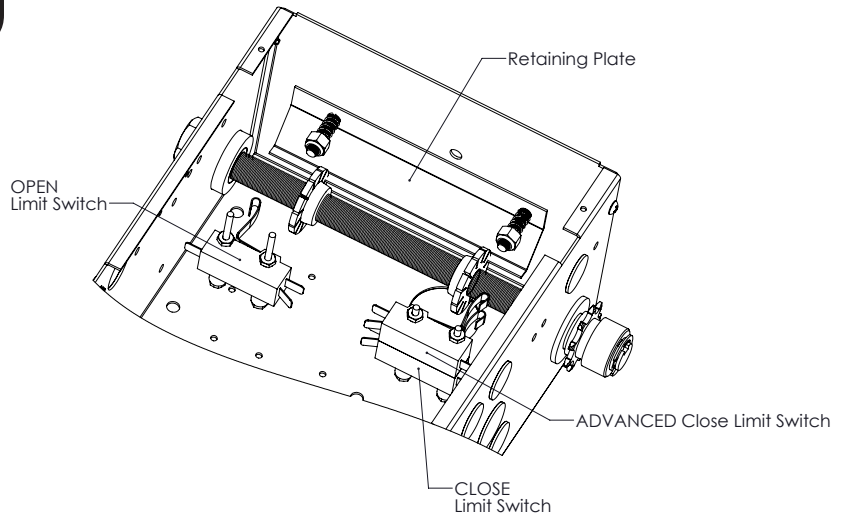

FIGURE 6

POWER WIRING

⚠ WARNING



To reduce the risk of SEVERE INJURY or DEATH:

- ANY maintenance to the operator or in the area near the operator **MUST NOT** be performed until disconnecting the electrical power and locking-out the power via the operator power switch. Upon completion of maintenance the area **MUST** be cleared and secured, at that time the unit may be returned to service.
 - **DISCONNECT** power at the fuse box **BEFORE** proceeding. Operator **MUST** be properly grounded and connected in accordance with local electrical codes. The operator should be on a separate fused line of adequate capacity.
 - **ALL** electrical connections **MUST** be made by a qualified individual.
 - **DO NOT** install **ANY** wiring or attempt to run the operator without consulting the wiring diagram. We recommend that you install an optional reversing edge **BEFORE** proceeding with the control station installation.
- **ALL** power wiring should be on a dedicated circuit and well protected. The location of the power disconnect should be visible and clearly labeled.
 - **ALL** power and control wiring must be run in separate conduit.
 - To avoid damage to door and operator, make **ALL** door locks inoperative. Secure lock(s) in "OPEN" position. If the door lock needs to remain functional, install an interlock switch.



POWER WIRING CONNECTIONS

1. DO NOT INSTALL ANY WIRING WITHOUT CONSULTING THE WIRING DIAGRAM.

The wiring diagram is included in this manual (page 14).

2. Be sure the power being supplied is of the correct voltage, phase, frequency, and amperage in accordance with the operator's serial tag.
3. Using a conduit access hole as shown below, bring supply lines to the operator and connect wires to the terminals indicated on the wiring diagram.
4. Important NOTE: Connect earth ground to the chassis ground screw in the electrical box enclosure. Do not turn power on until you have finished making all power and control wiring connections and have completed the limit switch adjustment procedure.

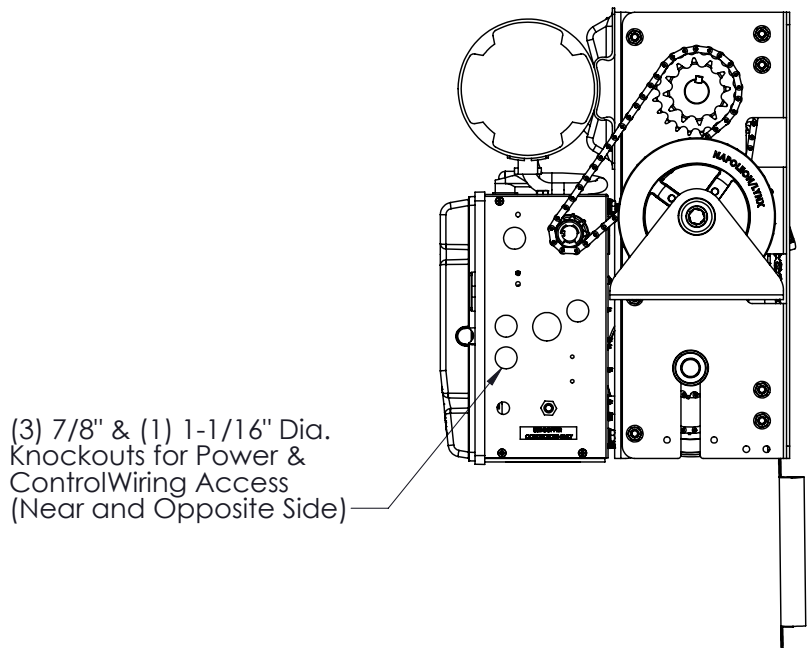

FIGURE 7

CONTROL WIRING

WIRING TYPE

MDJ, MDJH, MDJB, and MDJBH models are equipped with the LX900 board (programming and operation, page 11, field wiring, page 15). Upon installation the operator will be in C2 mode (which means only constant pressure will close the door).

To achieve B2 mode (where a momentary contact can be used to close the door) an entrapment protection device must be wired into the beam terminals according to the wiring diagram. Once the LX900 detects there is no obstruction it will switch to B2 Mode.

CONTROL STATION LOCATION

All operators are supplied with some type of control station. Generally a three button station (OPEN/CLOSED/STOP) is provided. Mount the control station within sight of the door, at a minimum of five (5) feet above the floor so children cannot reach it and away from any moving parts of the door.

RADIO CONTROL

All MDJ series operators have internal antenna's. LX900 compatible Single button, three button, or OPEN/CLOSE/STOP (OCS) transmitter(s) are optional accessories. While in B2 Mode, transmitters will operate the door the same as a wall control station. Also on all MDJ series operators, terminal strip is provided on the side of the electrical enclosure labeled as a 24 Volt Class 2 circuit and numbered (1,2,3). All standard radio receivers may be wired to this terminal strip. Single channel transmitters will then open a fully closed door, close a fully open door, and reverse a closing door from the radio transmitter. However, for complete door control from a remote, a commercial three-channel radio receiver (with connections for OPEN/CLOSE/STOP) is recommended.

ADDITIONAL ACCESS CONTROL EQUIPMENT

Locate any additional access control equipment as desired (but so that the door will be in clear sight of the person operating the equipment), and connect to the control board in accordance with the LX900 WIRING CONNECTIONS diagram. Any control with a normally open (N.O.) isolated output contact may be connected in parallel with the OPEN button or to the momentary switch terminals. More than one device may be connected in this manner. Use 18 gauge wire or larger for all controls.

External Interlock Switch

If an external interlock switch is required on the door, refer to the LX900 WIRING CONNECTIONS diagram for installation. This switch should have a contact rating of at least 3 amps @ 24VAC. The switch must be wired in series with the STOP or COM terminals so that the door will only operate while the switch is in its closed circuit state.

WARNING



To prevent possible **SERIOUS INJURY** or **DEATH**:

- Install the control station within sight of the door at a minimum of five (5) feet (to prevent operation by children), but away from the door and its hardware.
- Install reversing sensors when the 3-button control station is out of sight of the door or ANY other control (automatic or manual) is used. Reversing devices are recommended for ALL installations
- A reversing edge **MUST** be installed when a receiver is used to activate a commercial door opener.

IMPORTANT NOTE:

Mount warning notice beside or below the push button station.

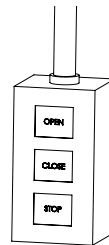

WARNING



To prevent possible **SERIOUS INJURY** or **DEATH** from a moving garage door:

- ALWAYS keep remote controls out of reach of children.
- NEVER permit children to operate, or play with remote controls.
- Activate gate or door ONLY when it can be seen clearly, is properly adjusted, and there are no obstructions to door travel.
- ALWAYS keep gate or garage door in sight until completely closed. NEVER permit anyone to cross path of moving gate or door.

PHOTO EYE INSTALLATION

PHOTO EYE INSTALLATION

1. Make sure that power is disconnected to the system prior to installing the photo eyes.
2. Photo eyes need to be mounted inside the building. They should be mounted on either side of the door and as close as possible to the door track to offer maximum safety precaution.
3. Photo eyes should be mounted no more than 6 inches from the floor. Both brackets need to be installed at the same height to allow them to align. **Note:** Use the following steps to install sensors on both sides of the door
4. Select a mounting location 5 inches above the floor to the centerline of the wall mounting "L" bracket. Mount the bracket to the wall. Repeat this step on the opposite side of the door.
5. Using the hardware provided, attach the photo eyes to the "L" brackets as shown in figure 11. Do not over tighten.

IMPORTANT NOTE:

Identify which side of the garage door is exposed to the most sunlight. Mount the sending unit (TX) on the side that is exposed to the most sun. Sunlight may affect the photo sensors and this orientation will help reduce the effect.

6. The transmitter and the receiver both have two 22-gauge wires coming from them. Uncoil the wires from the photo eyes and route them to the controller. Take one wire from the transmitter and one wire from the receiver (these wires have no polarity) and twist the stripped ends together. Repeat on the second wire from each unit. Connect the wires to the BEAM terminals. Again, polarity is not important.
7. At this time, you can reconnect the power to the operator. The LEDs on both transmitter and receiver will be lit if installed and aligned properly; the transmitter has a red LED, and the receiver has a green LED.
8. If the photo eyes are not aligned, refer to the chart in figure 10 for trouble shooting.
9. To test the photo eye system: open the door to the full open position. Close the door and as the door is closing, obstruct the beam. The door should stop and reverse to open.
10. Test the photo eye's function periodically.

Red LED	Green LED	Status
On	On	Normal Operation
Off	Off	No Power, Check wiring
2 x Blink	On	Bad alignment/ Obstructed beam/ Rx defective
3 x Blink	Off	Check power & wiring to Rx/ Rx defective
3 x Blink	On	Rx receiving sunlight/ interference

FIGURE 10

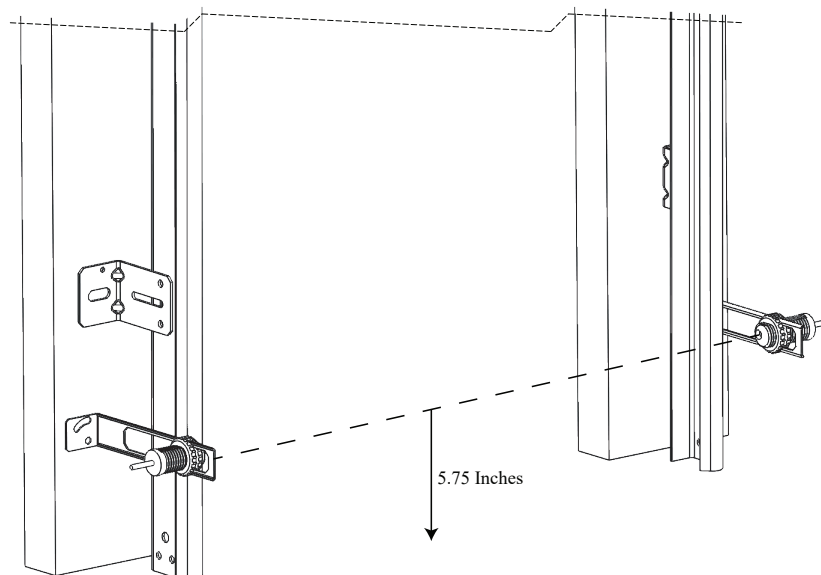

FIGURE 11

WARNING



To reduce the risk of serious injury or death, follow these instructions carefully:

- Read and follow ALL instructions.
- Keep fingers and other body parts away from all moving parts of the door and gate operator system while it is being operated.
- Keep the radio controls away from children. Do not allow children to play with the controls.
- Keep away from the door when it is in motion. Watch the door while it is moving until completely closed or opened.
- Do not cross the path of a moving door.
- Disable and locks and remove any ropes connected to the garage door to avoid entanglement and prevent damage to the system.
- Do not make repairs to cable, springs, or other hardware; call a trained door systems technician. The system is under extreme tension and can cause serious injury or death.
- Ensure that the door is properly operating and balanced. If not, call a trained door systems technician to make repairs.



MODES OF OPERATION

This controller has three (3) different modes of operation B2, C2, and TS (Timer Secure). Factory default is B2 mode and the Timer To Close (TTC) is 0 seconds. Anytime the operator does not detect safety beams, it will automatically change to C2 mode. If the TTC is larger than 0 seconds, it will automatically change to TS mode. There are 7 fixed delays for TTC – 3, 15, 30, 45, 60, 90 and 180 seconds. To adjust the setting, hold in the TTC button (refer to diagram). Three LED's above the TTC button will indicate the current setting on the adjacent chart. After reaching 180 seconds, it will jump back to 0 seconds (default) and the operator will revert to B2 Mode.

C2 Mode

- Momentary press of OPEN will open door.
- Constant pressure required on CLOSE for the door to close.
- Single or three button transmitter will open or stop the door only.

B2 Mode

- Momentary press of OPEN or CLOSE will activate door.
- Single button - reverses a closing door, stops an opening door.
- Transmitters activate operator same as wall stations.

TS Mode

- Button function is the same as B2 mode.
- Includes Timer to Close (TTC) function. The door will automatically close after set time expires. Timer starts when door reaches the open limit. (When first entering TS mode or after power interruption, momentary press of OPEN will start timer if door is at OPEN limit.)

General Notes regarding Mode of Operations:

- After power interruption the first move is Open.
- STOP button works in all modes of operation. If the 3 button wall station is not connected to the Control board or there is no jumper between COM and STOP, the motor will not run.
- The Constant Pressure (CP) feature will work only from 3 and 1 button wired Wall Station
- The controller includes a Run Timer: a maximum amount of time the motor will run after receiving either open or close command. Factory default: 45 seconds. Not adjustable.
- Open override means that the door may be reversed while closing by activating an OPEN button without the need to use the STOP button first (for all 3 Modes).

LX900 PROGRAMMING AND OPERATION

Programming a transmitter: To program a remote transmitter, press and hold the LEARN button for 3 seconds, the learn LED will turn ON and the operator will stay at LEARN mode for 15 seconds only. While in LEARN mode, press (any) button on the transmitter and notice that the LEARN LED will flash four (4) times, indicating that the transmitter has been programmed to the operator. The controller will learn up to 20 Lynx transmitters.

Erase all transmitters: To erase all remote transmitters, press and hold the LEARN button for at least 15 seconds. During this time observe that the learn LED will turn ON and, after about 10 seconds the LEARN LED will flash three (3) times indicating that all the transmitters have been erased from the operator.

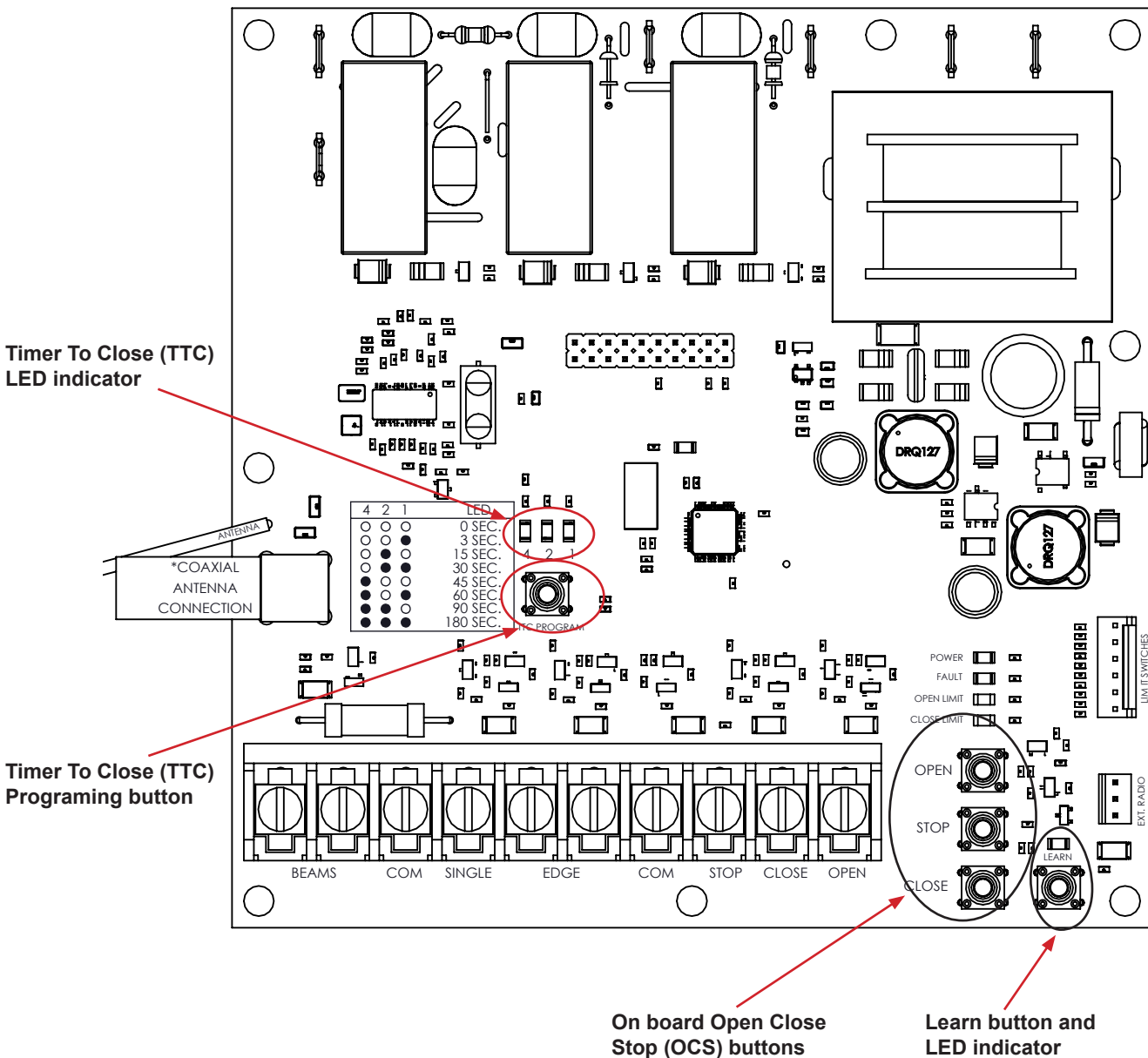

FIGURE 10

CLUTCH ADJUSTMENT

1. Loosen the adjustment jam nuts until there is little tension on the clutch spring.
2. Tighten the inner jam nut gradually until there is just enough tension to permit the operator to move the door smoothly but to allow the clutch to slip if the door is obstructed. When the clutch is properly adjusted, it should generally be possible to stop the door by hand during travel.
3. Tighten the outer jam nut and lock the nuts in place by tightening them against one another.

IMPORTANT NOTE:

The adjustable friction clutch is NOT an automatic reversing device.

⚠ WARNING

To prevent possible SERIOUS INJURY or DEATH, install reversing sensors when the 3-button control station is out of sight of the door or any other control (automatic or manual) is used. Reversing devices are recommended for ALL installations.

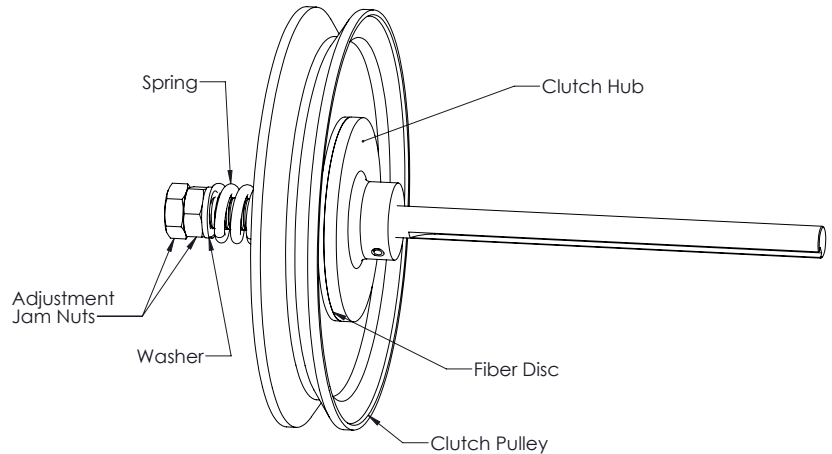

BRAKE ADJUSTMENT

On models LDJB and LDJBH a brake is supplied from the factory. It is designed to stop and hold the door in position whenever power is removed from the motor.

On first installation the brake should not need adjustment. The brake operation should be inspected every 3 months. As the brake pads wear, adjustments need to be made to maintain proper operation.

With the power disconnected to the operator, carefully try to rotate the large drive pulley by hand. The brake should be engaged and it should be very difficult to turn.

While pushing the solenoid plunger in by hand, there should now be clearance between the brake pads and the drum (approximately .020") allowing the pulley to rotate freely. To achieve the proper operation, adjust the upper and lower pad spacing bolts (A&B) accordingly.

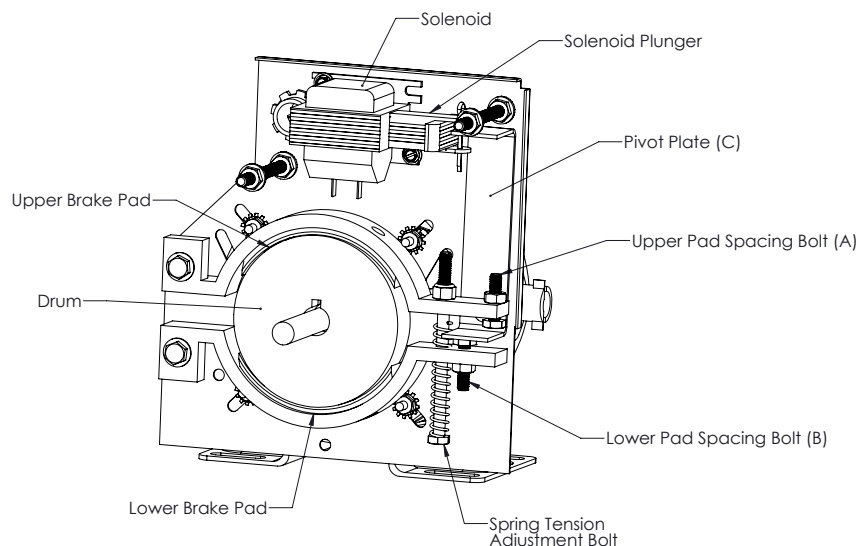

TESTING THE SYSTEM

Turn on the power to the operator. Test all controls and safety devices to make sure they are working properly. Refer to the previous instructions in this manual to make necessary adjustments.

IMPORTANT NOTE:

Do not leave operator power on unless all safety and entrapment devices have been tested and are working properly. Be sure you have read and understand all Safety Instructions in this manual.

IMPORTANT NOTE:

Be sure the owner or person(s) responsible for the operation of the door have read and understand the Safety Instructions, know how to electrically operate the door in a safe manner, and know how to use the manual disconnect operation of the door system.

MAINTENANCE SCHEDULE

IMPORTANT NOTE:

Do not...

- Use grease or silicone spray
- Lubricate motor
- Lubricate Clutch or V-belt

Do...

- Disconnect ALL electric power BEFORE performing any maintenance.
- Use SAE 30 Oil.
- Inspect and service whenever a malfunction is observed or suspected.

WARNING



To avoid **SERIOUS PERSONAL INJURY or DEATH** from **electrocution**, disconnect ALL electric power BEFORE performing ANY maintenance.

ITEM	PROCEDURE	EVERY 3 MONTHS	EVERY 6 MONTHS
Drive Chain	Check for excessive slack, adjust as needed.	●	
	Lubricate.	●	
Sprockets	Check for set screw tightness.	●	
Clutch	Check, adjust as needed.		●
Belt	Check condition & tightness.		●
Fasteners	Check, tighten if needed.		●
Manual Disconnect	Check & operate.		●
Brake (if present)	Check, adjust as needed.	●	

WIRING DIAGRAM (FACTORY)

LDJ

14

MDJ, MDJH, MDJB, MDJBH

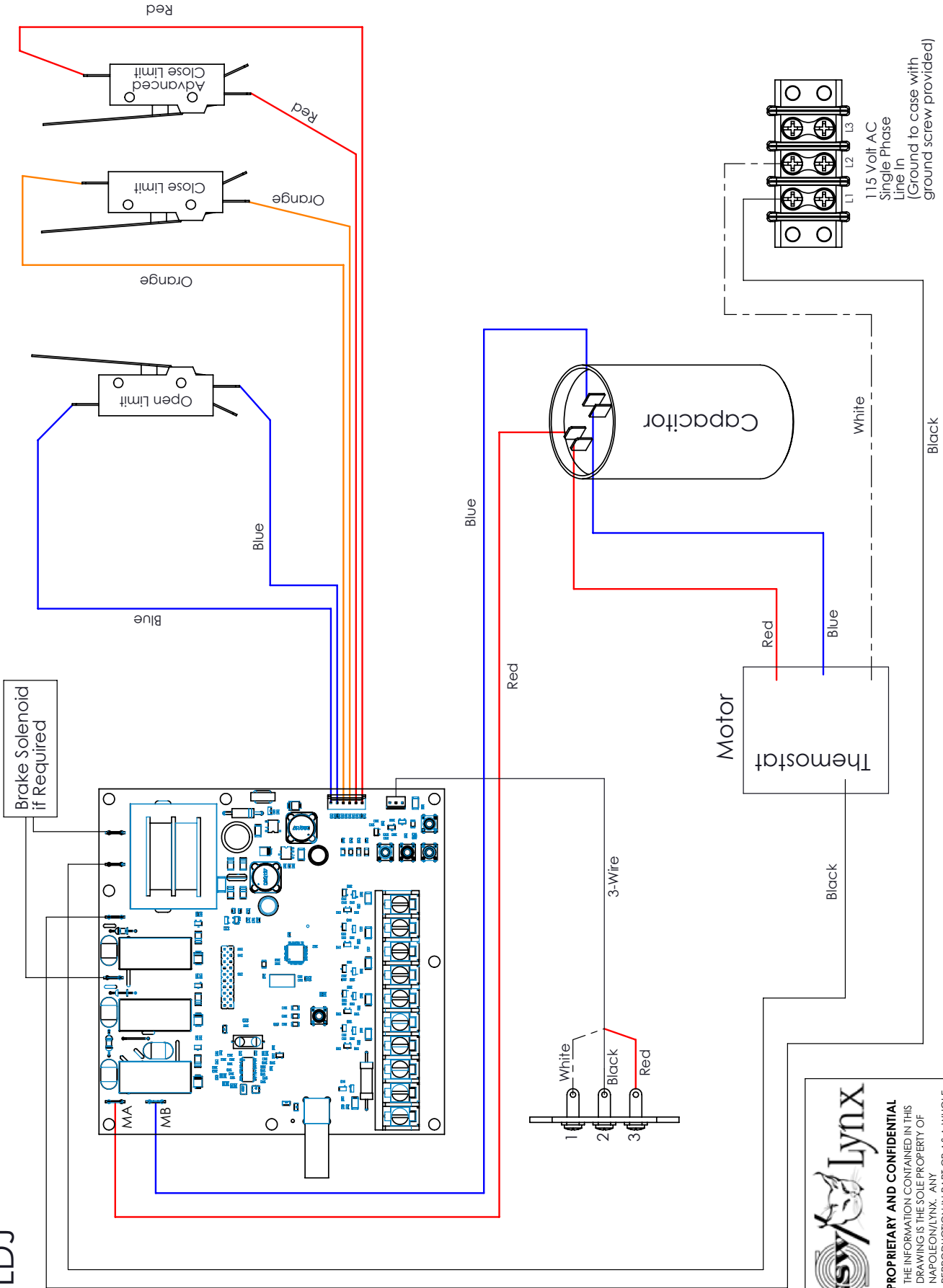

PROPRIETARY AND CONFIDENTIAL
 THE INFORMATION CONTAINED IN THIS DRAWING IS THE SOLE PROPERTY OF NAPOLEON/LYNX. ANY REPRODUCTION IN PART OR AS A WHOLE WITHOUT THE WRITTEN PERMISSION OF NAPOLEON/LYNX IS PROHIBITED.

REV. 05/28/14

LX-900 Wiring Connections

WIRING DIAGRAM (FIELD)

****Stop and Com must be jumpered when a 3-Button Wall Station is not Present**

***IF USING COAXIAL ANTENNA CUT PROVIDED ANTENNA NEAR CIRCUIT BOARD**

***COAXIAL ANTENNA CONNECTION**



Rev.
09/11/15

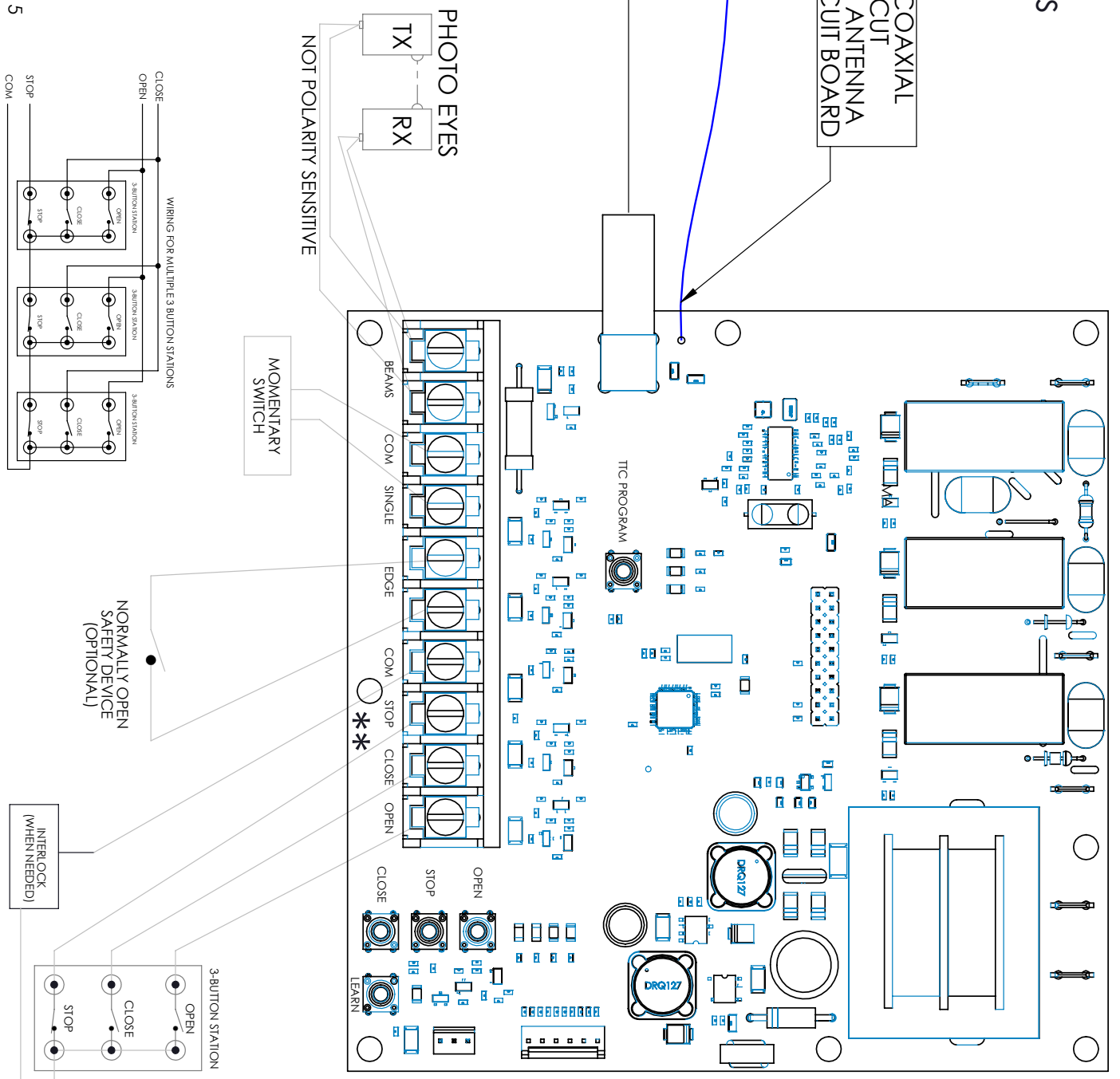

WIRING FOR MULTIPLE 3-BUTTON STATIONS

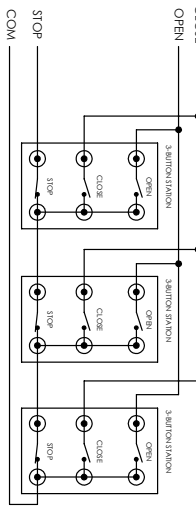

NORMALLY OPEN SAFETY DEVICE (OPTIONAL)

INTERLOCK (WHEN NEEDED)

3-BUTTON STATION

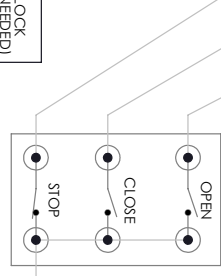

SHOP DRAWING

