

OWNER'S MANUAL

MEDIUM DUTY JACK SHAFT OPERATOR

MODEL NO.

MCJ, MCJH, MCJB, MCJBH

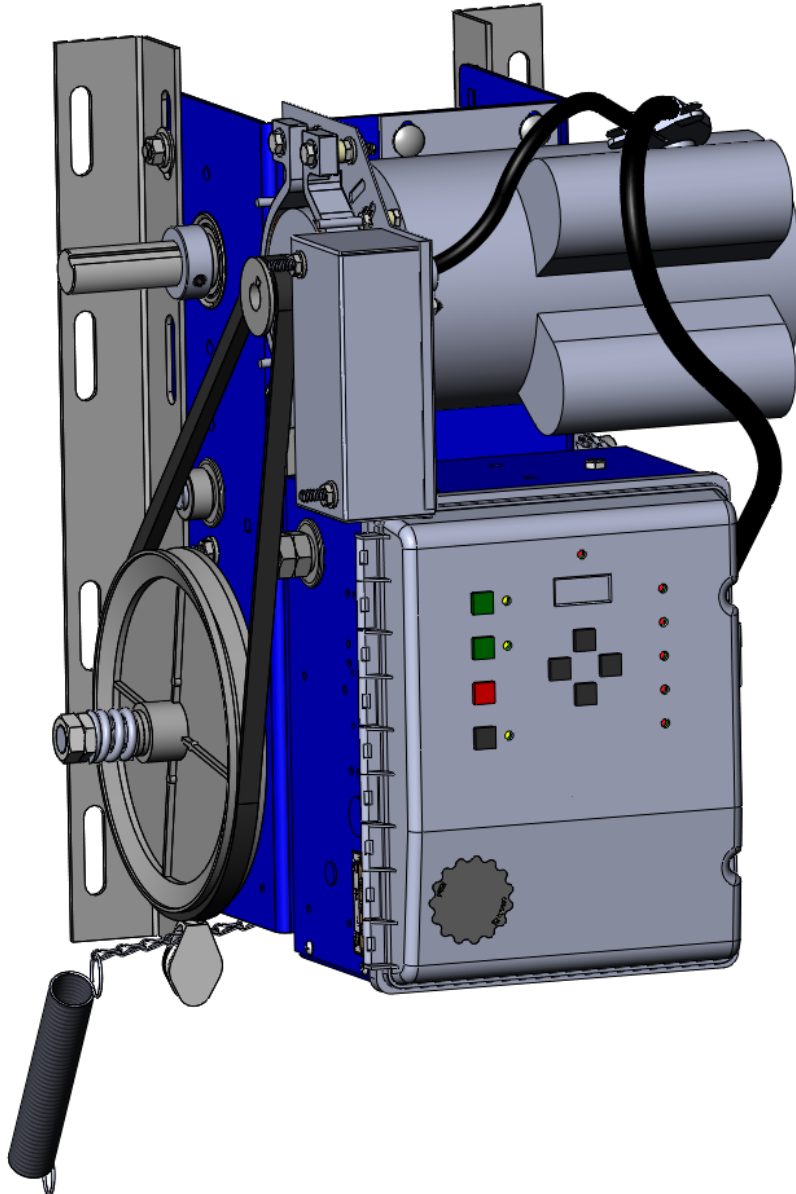

Napoleon/Lynx™

**READ AND FOLLOW ALL INSTALLATION INSTRUCTIONS
SAVE THESE INSTRUCTIONS**

NOT FOR RESIDENTIAL USE

This unit is intended for limited duty applications not to exceed 12 cycles of opening and closing per hour.

SPECIFICATIONS

MOTOR

TYPE:	Continuous Duty
HP:	1/2, 3/4, and 1 HP
SPEED:	1650 RPM
VOLTAGE:	115/230V 1 phase, 208/230/380/460/575V 3 Phase
CURRENT:	See motor nameplate

ELECTRICAL

TRANSFORMER:	24VAC
CONTROL STATION:	3-button station OPEN/CLOSE/STOP
WIRING TYPE:	B2 (Standard, when powered)
	C2 (When photoeyes are blocked or not present)
LIMIT ADJUST:	Linear driven, fully adjustable screw type cams. Adjustable to 24 feet.

MECHANICAL

DRIVE REDUCTION:	Primary: Heavy duty (4L) V-Belt
	Secondary: #48 chain/sprocket
	Output: #41 chain
OUTPUT SHAFT SPEED:	52 RPM
DOOR SPEED:	Approx. 5.4" per sec. depending on door.
BRAKE (Optional):	Solenoid actuated drum brake
BEARINGS:	Ball bearing with hardened races.
HAND CHAIN WHEEL(optional):	Center

SAFETY

DISCONNECT:	All Models: Floor level disconnect for manual door operation.
REVERSING EDGE:	(Optional) Electric or pneumatic sensing device attached to the bottom edge of door. A REVERSING EDGE IS STRONGLY RECOMMENDED FOR ALL COMMERCIAL OPERATOR INSTALLATIONS. REQUIRED WHEN THE 3 BUTTON CONTROL STATION IS OUT OF SIGHT OF DOOR OR ANY OTHER CONTROL (AUTOMATIC OR MANUAL) IS USED.

DIMENSIONS & WEIGHT

HANGING WEIGHT:	55-60 LBS
SHIPPING WEIGHT:	70-85 LBS

SAFETY

WARNING



Improperly operating or an unbalanced door could cause SERIOUS INJURY or DEATH. See Door

Manufacturer's Owner's Manual. Have trained door systems technicians make repairs to cables, spring assemblies, and other hardware.

WARNING



To prevent SERIOUS INJURY or DEATH:

- DO NOT connect electric power until instructed to do so.



- ALWAYS call a trained professional door serviceman if door binds, sticks or is out of balance. An unbalanced door may not reverse when required.

- NEVER try to loosen, move or adjust doors, door springs, cables, pulleys, brackets or their hardware,

ALL of which are under EXTREME tension and can cause SERIOUS PERSONAL INJURY.

- DISABLE ALL locks and remove ALL ropes connected to door BEFORE installing and operating door operator to avoid entanglement.

PREPARATION

It is imperative that the wall or mounting surface provide adequate support for the operator.

The surface must:

- a. Be rigid to prevent play between operator and door shaft. (Spreader bars will also be of aid when the door shaft is not supported properly by an end bearing)
- b. Provide a level base
- c. Permit the operator to be fastened securely and with the drive shaft parallel to the door shaft.

The safety and wear of the operator will be adversely effected if any of the above requirements are not met.

For metal buildings, fasten 2" x 2" x 3/16" (or larger) angle iron frames to the building purlins. Retain 7-1/2" between frames (Figure 1).

All MCJ, MCJH, MCJB, and MCJBH operators have dual output shafts and may be mounted on either the right (standard) or the left side of the door. Install the sprocket on the side desired and insert the key. Be sure to tighten Both set screws securely.

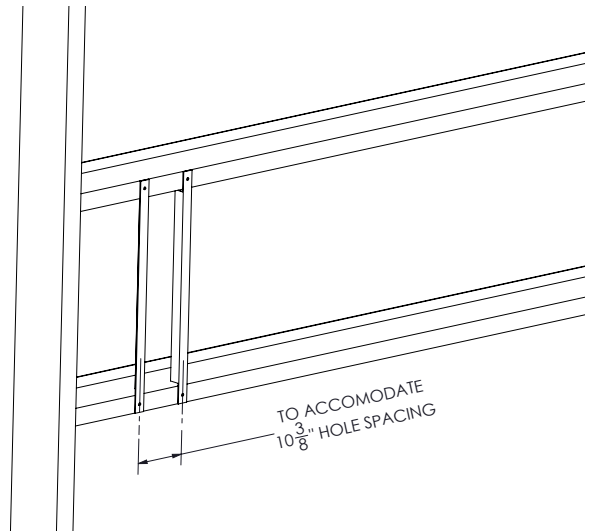

IMPORTANT NOTE: To aid installation, see page 29 (Shop Drawing) for mounting consideration.

INSTALLATION

⚠ WARNING



Moving parts on the operator could cause possible **SERIOUS INJURY**. Install the operator at least 8 feet above the floor to keep people away from the moving parts.

IMPORTANT NOTE: Before your operator is installed, be sure the door has been properly aligned, balanced, and is working smoothly.

1. Wall Mount:

- A The operator should generally be installed below the door shaft, and as close to the door as possible. The optimum distance between the door shaft and operator drive shaft is between 12-1/2" - 15-1/2" (Figure 2)
- B Place the door sprocket on the door shaft. Do not insert the key at this time.
- C Ensure the drive sprocket on the operator is on the appropriate side.
- D Wrap the drive chain around the door sprocket and join the roller chains end together with master link. (NOTE: The chain may need to be made shorter depending on the operator mounting position)
- E Raise the operator to approximate mounting position and position the chain over the operator drive sprocket.
- F Raise or lower the operator until the chain is taut (not tight). Make sure the operator output shaft is parallel to the door shaft and secure the operator in position.
- G Align the door sprocket to the operator drive sprocket (Figure 3), insert the key, and secure with BOTH set screws.

2. **Install Hand Chain (Models MCJH and MCJBH only):** Thread hand chain around hand chain wheel ensuring that it passes through both openings in the hand chain guide. Remove enough links that so that the loop hangs approximately two feet above the floor.

3. **Mount Manual Disconnect/Chain Keeper:** Using suitable hardware, mount the manual disconnect directly beneath the operator approximately four (4) feet above the floor. Install the sash chain on the spring that hangs from the operator and secure to the disconnect handle so that the handle is held vertically upright by the sash chain (Figure 4, page 5). Pulling down on the disconnect handle should disengage the motor from door assembly allowing for manual operation.

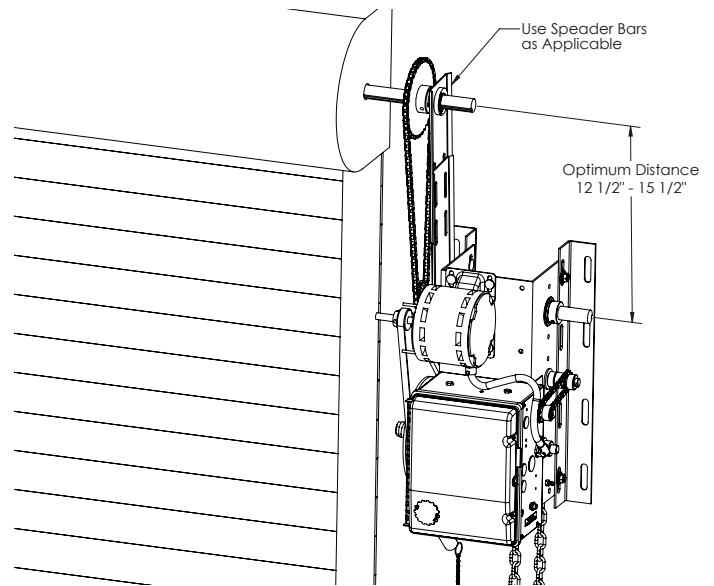

FIGURE 2

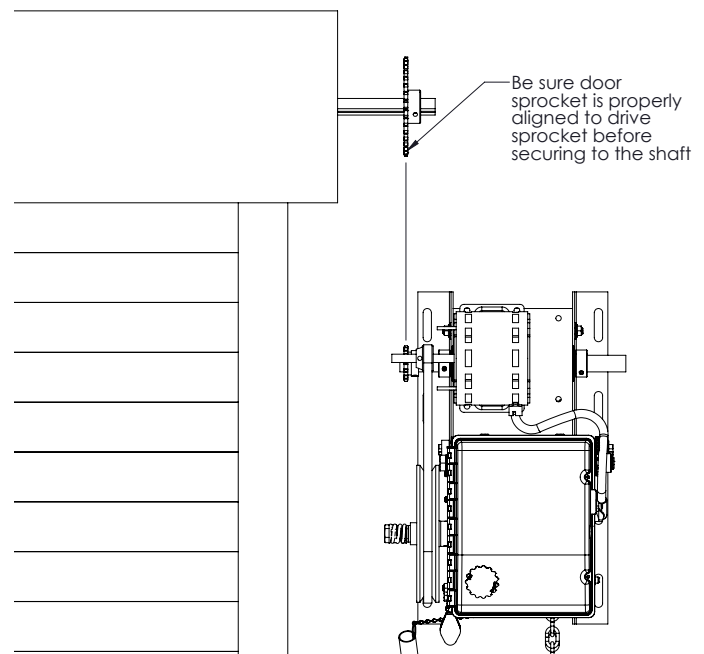

FIGURE 3

MANUAL OPERATION

WARNING



Moving chain could cause possible **SERIOUS INJURY**. **DISCONNECT** electric power to the operator **BEFORE** manually operating your door



WARNING



Broken Spring(s) may cause the door to fall rapidly, causing **SEVERE INJURY** or **DEATH**. If possible only use the manual release when the door is closed, otherwise use caution when using the release while the door is open.

This operator has provisions for manually operating the door in case of emergency or power failure.

1. Pull the disconnect arm down until it is retained behind the return flange on the bottom side (Figure 5). This will disengage the motor. It will also engage the hoist mechanism if present.
2. Operate the door manually as desired.
3. To return to electrical operation, return the disconnect arm to the upright position (Figure 4).

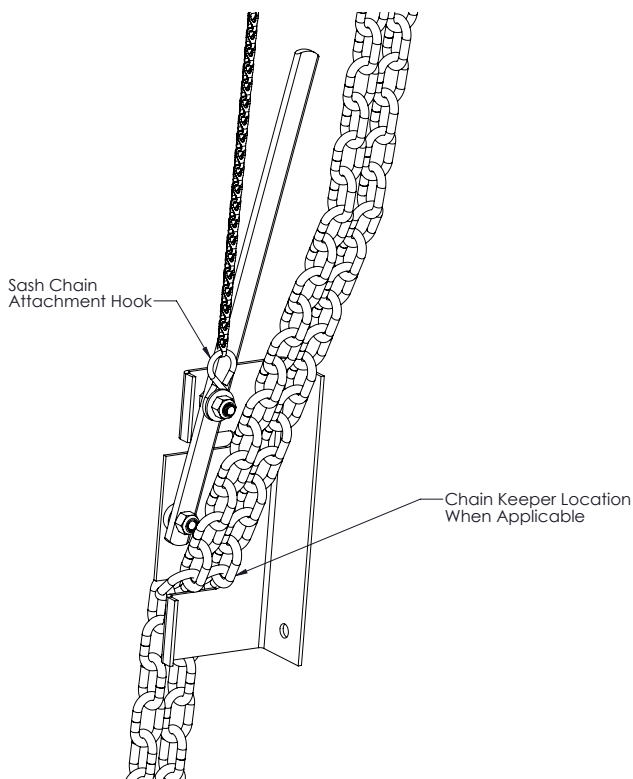

FIGURE 4

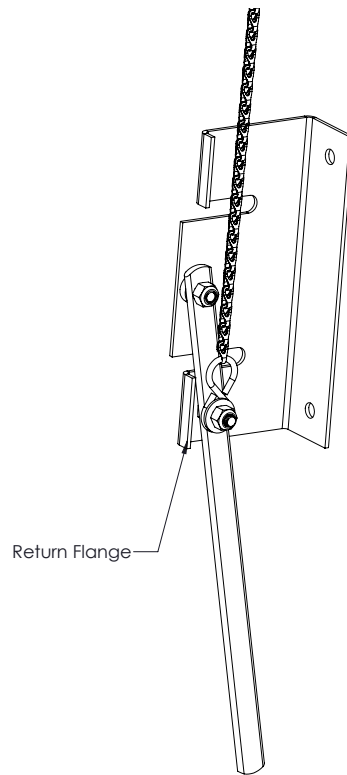

FIGURE 5

ENTRAPMENT PROTECTION ACCESSORIES (OPTIONAL)

SENSING EDGES

All types of sensing edges with an isolated normally open (N.O.) output are compatible with your operator. This includes pneumatic and electric edges. If your door does not have a bottom sensing edge and you wish to purchase one, contact the supplier of your operator.

If not pre-installed by the door manufacturer, mount the sensing edge on the door according to the instructions provided with the edge. The sensing edge may be electrically connected by either coiled cord or take-up reel.

IMPORTANT NOTES:

- Proceed with Limit Switch adjustments before making any sensing edge wiring connections to operator as described below.
- Electrician must hardwire the junction box to the operator electrical box in accordance with local codes.

⚠️ WARNING



To reduce risk of **SEVERE INJURY or DEATH**, ALWAYS install reversing sensors when the 3-button control station is out of sight of door or ANY other control (automatic or manual) is used. Reversing devices are recommended for all installations.

WIRING: For wiring of your sensing device to the operator, refer to the wiring diagram supplied with your operator. See field connection terminals identified as Safety Device.

TAKE-UP REEL: Take-up reel should be installed 12" above the top of the door.

COIL CORD: Connect operator end of coil cord to junction box (not supplied) fastened to the wall approximately halfway up the door opening.

LIMIT SWITCH ADJUSTMENT

⚠️ WARNING



To avoid **SERIOUS PERSONAL INJURY or DEATH** from **electrocution**, disconnect electric power **BEFORE** manually moving limit nuts.

IMPORTANT NOTE: Make sure the limit nuts are positioned between the limit switch actuators before proceeding with adjustments.

- To adjust limit nuts depress retaining plate to allow nut to spin freely. After adjustment, release plate and ensure it seats fully in slots of both nuts.
- To increase door travel, spin nut away from actuator. To decrease door travel, spin limit nut toward actuator.
- Adjust open limit nut so that door will stop in open position with the bottom of the door even with top of door opening.
- Repeat Steps 1 and 2 for close cycle. Adjust close limit nut so that actuator is engaged as door fully seats at the floor.

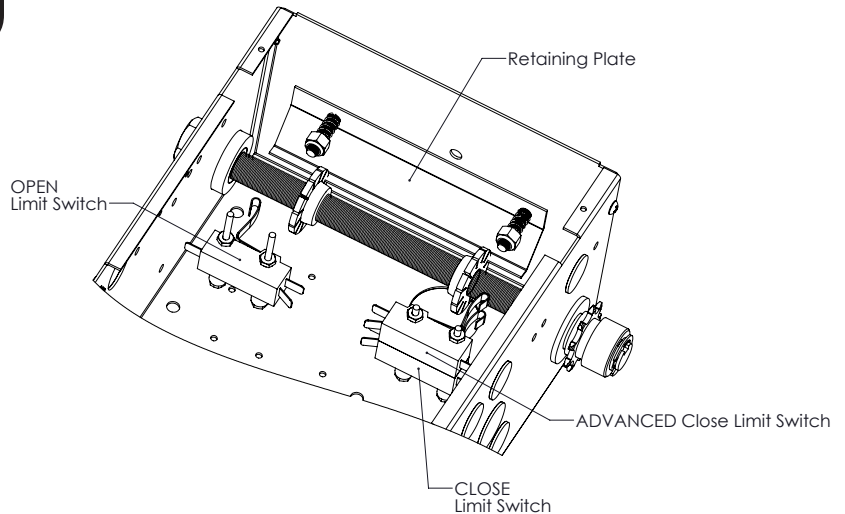

FIGURE 6

POWER WIRING

⚠ WARNING



To reduce the risk of SEVERE INJURY or DEATH:

- ANY maintenance to the operator or in the area near the operator **MUST NOT** be performed until disconnecting the electrical power and locking-out the power via the operator power switch. Upon completion of maintenance the area **MUST** be cleared and secured, at that time the unit may be returned to service.
 - **DISCONNECT** power at the fuse box **BEFORE** proceeding. Operator **MUST** be properly grounded and connected in accordance with local electrical codes. The operator should be on a separate fused line of adequate capacity.
 - **ALL** electrical connections **MUST** be made by a qualified individual.
 - **DO NOT** install ANY wiring or attempt to run the operator without consulting the wiring diagram. We recommend that you install an optional reversing edge **BEFORE** proceeding with the control station installation.
- **ALL** power wiring should be on a dedicated circuit and well protected. The location of the power disconnect should be visible and clearly labeled.
 - **ALL** power and control wiring must be run in separate conduit.
 - To avoid damage to door and operator, make **ALL** door locks inoperative. Secure lock(s) in "OPEN" position. If the door lock needs to remain functional, install an interlock switch.



POWER WIRING CONNECTIONS

1. DO NOT INSTALL ANY WIRING WITHOUT CONSULTING THE WIRING DIAGRAM.

The wiring diagram is included in this manual (page 20-28).

2. Be sure the power being supplied is of the correct voltage, phase, frequency, and amperage in accordance with the operator's serial tag.
3. Using a conduit access hole as shown below, bring supply lines to the operator and connect wires to the terminals indicated on the wiring diagram.
4. Important NOTE: Connect earth ground to the chassis ground screw in the electrical box enclosure. Do not turn power on until you have finished making all power and control wiring connections and have completed the limit switch adjustment procedure.

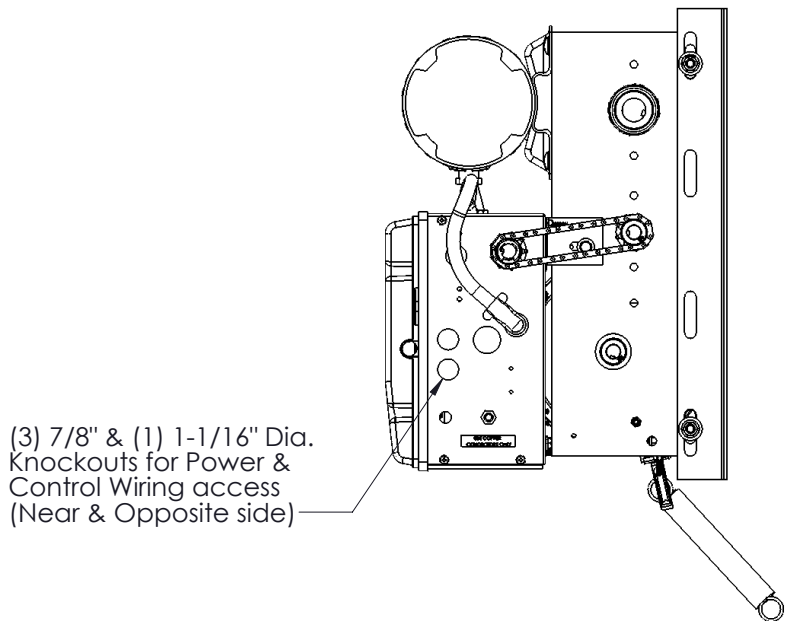

FIGURE 7

CONTROL WIRING

WIRING TYPE

The MCJ model is equipped with the LX100 board (programming and operation, page 13-19, wiring diagrams, pages 20-28).

CONTROL STATION LOCATION

All operators are supplied with some type of control station. Generally a three button station (OPEN/CLOSED/STOP) is provided. Mount the control station within sight of the door, at a minimum of five (5) feet above the floor so small children cannot reach it, and away from all moving parts of the door.

RADIO CONTROL

The MCJ series operator has an internal antenna. LX100 compatible Single button, three button, or OPEN/CLOSE/STOP (OCS) transmitter(s) are optional accessories. While in B2 Mode, transmitters will operate the door the same as a wall control station. Also on all MCJ series operators, terminal strip is provided on the side of the electrical enclosure labeled as a 24 Volt Class 2 circuit and numbered (1,2,3). All standard radio receivers may be wired to this terminal strip. Single channel transmitters will then open a fully closed door, close a fully open door, and reverse a closing door from the radio transmitter. However, for complete door control from a remote, a commercial three-channel radio receiver (with connections for OPEN/CLOSE/STOP) is recommended.

ADDITIONAL ACCESS CONTROL EQUIPMENT

Locate any additional access control equipment as desired (but so that the door will be in clear sight of the person operating the equipment), and connect to the control board in accordance with the LX100 WIRING CONNECTIONS diagram. Any control with a normally open (N.O.) isolated output contact may be connected in parallel with the OPEN button or to the momentary switch terminals. More than one device may be connected in this manner. Use 18 gauge wire or larger for all controls.

External Interlock Switch

If an external interlock switch is required on the door, refer to the LX100 WIRING CONNECTIONS diagram for installation. This switch should have a contact rating of at least 3 amps @ 24VAC. The switch must be wired in series with the STOP or COM terminals so that the door will only operate while the switch is in its closed circuit state. LX100 can use "Pass Door" terminals for interlock.

! WARNING



To prevent possible **SERIOUS INJURY** or **DEATH**:

- Install the control station within sight of the door at a minimum of five (5) feet (to prevent operation by children), but away from the door and its hardware.
- Install reversing sensors when the 3-button control station is out of sight of the door or ANY other control (automatic or manual) is used. Reversing devices are recommended for ALL installations
- A reversing edge **MUST** be installed when a receiver is used to activate a commercial door opener.

IMPORTANT NOTE:

Mount warning notice beside or below the push button station.

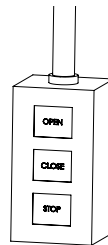

! WARNING



To prevent possible **SERIOUS INJURY** or **DEATH** from a moving garage door:

- ALWAYS keep remote controls out of reach of children.
- NEVER permit children to operate, or play with remote controls.
- Activate gate or door ONLY when it can be seen clearly, is properly adjusted, and there are no obstructions to door travel.
- ALWAYS keep gate or garage door in sight until completely closed. NEVER permit anyone to cross path of moving gate or door.

PHOTO EYE INSTALLATION

PHOTO EYE INSTALLATION

1. Make sure that power is disconnected to the system prior to installing the photo eyes.
2. Photo eyes need to be mounted inside the building. They should be mounted on either side of the door and as close as possible to the door track to offer maximum safety precaution.
3. Photo eyes should be mounted no more than 6 inches from the floor. Both brackets need to be installed at the same height to allow them to align.
4. Select a mounting location 5 inches above the floor to the centerline of the wall mounting “L” bracket. Mount the bracket to the wall. Repeat this step on the opposite side of the door.
5. Using the wing nuts provided, attach the photo eyes to the “L” brackets with the arrows pointing up. Do not over tighten.

IMPORTANT NOTE:

Identify which side of the garage door is exposed to the most sunlight. Mount the sending unit (TX) on the side that is exposed to the most sun. Sunlight may affect the photo sensors and this orientation will help reduce the effect.

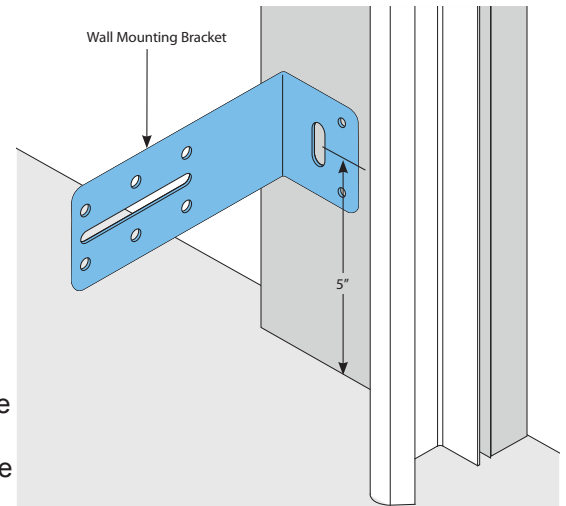

FIGURE 8

6. The transmitter and the receiver both have two 22-gauge wires coming from them. Uncoil the wires from the photo eyes and route them to the controller. Take one wire from the transmitter and one wire from the receiver (these wires have no polarity) and twist the stripped ends together. Repeat on the second wire from each unit. Connect the wires to the BEAM terminals. Again, polarity is not important.
7. At this time, you can reconnect the power to the operator. The LEDs on both transmitter and receiver will be lit if installed and aligned properly; the transmitter has a red LED, and the receiver has a green LED.
8. If the photo eyes are not aligned, then the green LED on the receiver will be off. To align the photo eyes, you can adjust the position of the transmitter or the receiver on the slot of the bracket until both LEDs are lit. Tighten the brackets.
9. To test the photo eye system: open the door to the full open position. Close the door and as the door is closing, obstruct the beam. The door should stop and reverse to open.
10. Test the photo eye's function periodically.

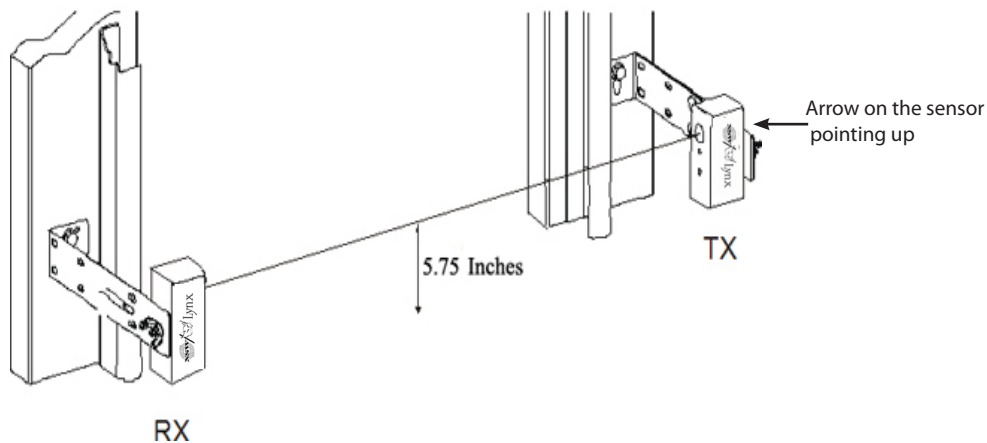

FIGURE 9

CLUTCH ADJUSTMENT

1. Loosen the adjustment jam nuts until there is little tension on the clutch spring.
2. Tighten the inner jam nut gradually until there is just enough tension to permit the operator to move the door smoothly but to allow the clutch to slip if the door is obstructed. When the clutch is properly adjusted, it should generally be possible to stop the door by hand during travel.
3. Tighten the outer jam nut and lock the nuts in place by tightening them against one another.

IMPORTANT NOTE:

The adjustable friction clutch is NOT an automatic reversing device.

⚠ WARNING

To prevent possible SERIOUS INJURY or DEATH, install reversing sensors when the 3-button control station is out of sight of the door or any other control (automatic or manual) is used. Reversing devices are recommended for ALL installations.

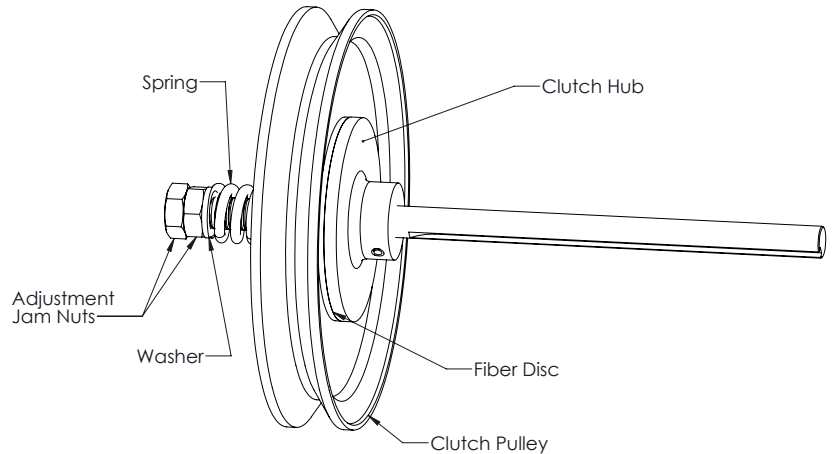

BRAKE ADJUSTMENT

On models MCJB and MCJBH a brake is supplied from the factory. It is designed to stop and hold the door in position whenever power is removed from the motor.

On first installation the brake should not need adjustment. The brake operation should be inspected every 3 months. As the brake pads wear, adjustments need to be made to maintain proper operation.

With the power disconnected to the operator, carefully try to rotate the large drive pulley by hand. The brake should be engaged and it should be very difficult to turn.

While pushing the solenoid plunger in by hand, there should now be clearance between the brake pads and the drum (approximately .020") allowing the pulley to rotate freely. To achieve the proper operation, adjust the upper and lower pad spacing bolts (A&B) accordingly.

⚠ WARNING

To avoid SERIOUS PERSONAL INJURY or DEATH from electrocution, DISCONNECT electric power BEFORE performing any maintenance

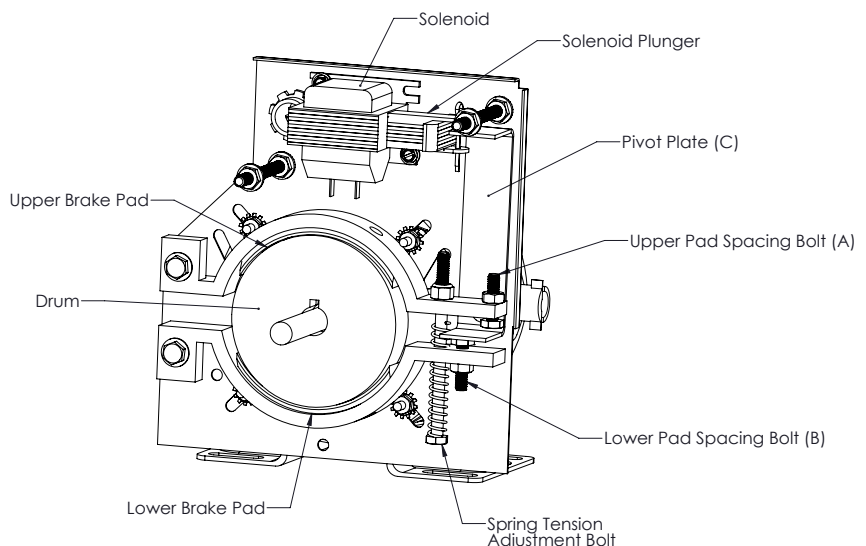

TESTING THE SYSTEM

Turn on the power to the operator. Test all controls and safety devices to make sure they are working properly. Refer to the previous instructions in this manual to make necessary adjustments.

IMPORTANT NOTE:

Do not leave operator power on unless all safety and entrapment devices have been tested and are working properly. Be sure you have read and understand all Safety Instructions in this manual.

IMPORTANT NOTE:

Be sure the owner or person(s) responsible for the operation of the door have read and understand the Safety Instructions, know how to electrically operate the door in a safe manner, and know how to use the manual disconnect operation of the door system.

MAINTENANCE SCHEDULE

IMPORTANT NOTE:

Do not...

- Use grease or silicone spray
- Lubricate motor
- Lubricate Clutch or V-belt

Do...

- Disconnect ALL electric power BEFORE performing any maintenance.
- Use SAE 30 Oil.
- Inspect and service whenever a malfunction is observed or suspected.

⚠ **WARNING**



To avoid **SERIOUS PERSONAL INJURY or DEATH** from **electrocution**, disconnect ALL electric power BEFORE performing ANY maintenance.

ITEM	PROCEDURE	EVERY 3 MONTHS	EVERY 6 MONTHS
Drive Chain	Check for excessive slack, adjust as needed.	●	
	Lubricate.	●	
Sprockets	Check for set screw tightness.	●	
Clutch	Check, adjust as needed.		●
Belt	Check condition & tightness.		●
Fasteners	Check, tighten if needed.		●
Manual Disconnect	Check & operate.		●
Brake (if present)	Check, adjust as needed.	●	

LX900 PROGRAMMING AND OPERATION

WARNING



To reduce the risk of serious injury or death, follow these instructions carefully:

- Read and follow ALL instructions.
- Keep fingers and other body parts away from all moving parts of the door and gate operator system while it is being operated.
- Keep the radio controls away from children. Do not allow children to play with the controls.
- Keep away from the door when it is in motion. Watch the door while it is moving until completely closed or opened.
- Do not cross the path of a moving door.
- Disable and locks and remove any ropes connected to the garage door to avoid entanglement and prevent damage to the system.
- Do not make repairs to cable, springs, or other hardware; call a trained door systems technician. The system is under extreme tension and can cause serious injury or death.
- Ensure that the door is properly operating and balanced. If not, call a trained door systems technician to make repairs.



Controller front view

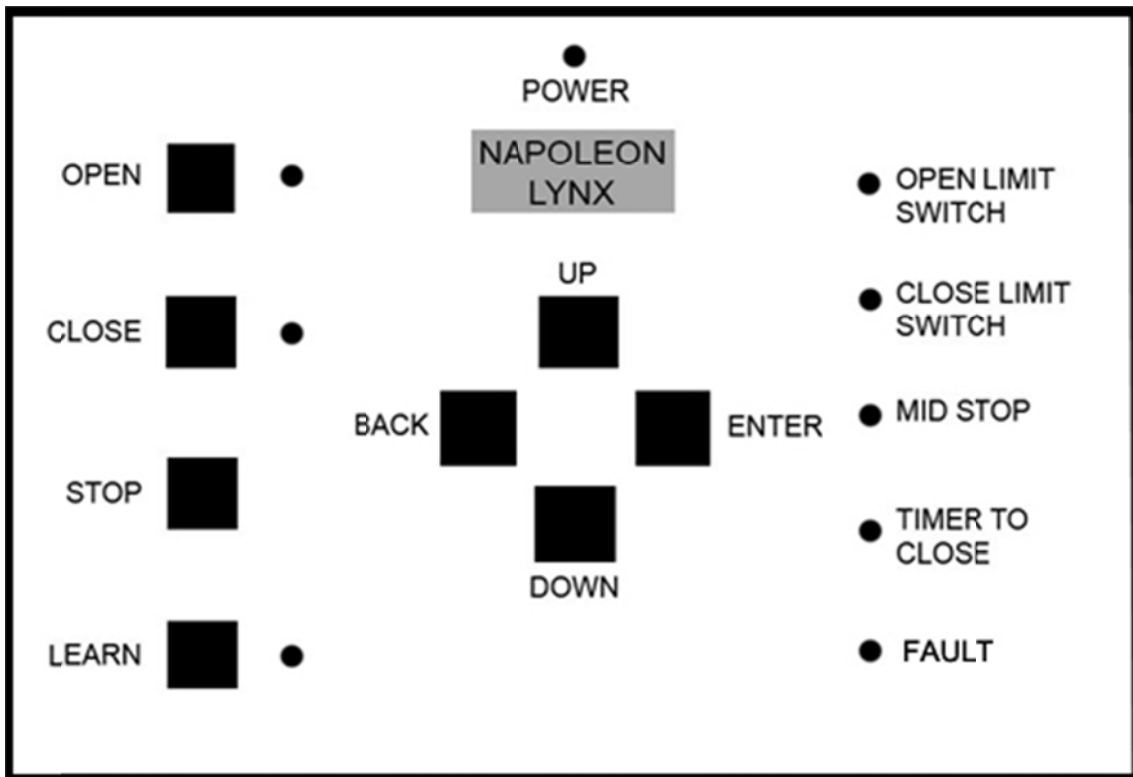

Basic Operation:

Security feature:

Within a certain time, the front panel will lock itself for security reasons. When you approach the operator and the LCD screen is dark, the device is locked. To unlock the operator, press ENTER and then follow the instructions on the LCD screen. After unlocking the system, the display will read “Main Menu”. Press BACK to return to “Napoleon Lynx” and Run Mode. The operator is in run mode when the LCD screen says “Napoleon Lynx”. In this mode, the front panel controls will function for normal door operation.

Operation from the Front Panel:

OPEN

If the door is stopped, pressing the button will open the door.
If it is opening or at open limit, pressing the button will do nothing.
If it is closing, pressing the button will stop the door and then open it.
Open LED is lit when door is opening.
Open Limit Switch LED blinks when the door is opening and is solid when the door is at open limit.

CLOSE

If the door is stopped, pressing the button will close the door.
If it is closing or at close limit, pressing the button will do nothing.
If it is opening, pressing the button will do nothing.
Close LED is lit when door is closing.
Close Limit Switch LED blinks when door is closing and is solid when door is at close limit.

STOP

Pressing the button will stop door motion.
If the door is not moving, pressing the button will do nothing.
Pressing stop disables TTC if set.

LEARN

Press and hold the LEARN button for about 3 seconds until the Learn LED lights to program a remote. The LED is solid when looking for a signal from a remote. At this time, press the button on the radio control you wish to program and the Learn LED will blink four (4) times to indicate that the radio control has learned to interact with the operator.
If no transmitter is learned within 15 seconds, the LED will turn OFF and the learn function is disabled.
To erase all stored transmitters, hold the LEARN button for 10 seconds. The LED will blink several times to indicate that all transmitters were cleared.
A maximum of 20 different transmitters can be learned by the on board receiver.

Navigation Keys

- Up, Down, Enter, and Back
- Enter Key: Press to enter programming mode from main screen or to select current menu option.
 - Back Key: Press to move back in the menu, or to cancel current option.
 - Up Key: Press to move up in the menu.
 - Down Key: Press to move down in the menu.

LED Indicators

Mid-Stop LED is lit when the door is at the mid-stop position defined by the user.
Timer to Close (TTC) LED blinks when the door is open and the timer to close is active.
Fault LED is lit when the photo beam or the safety edge is blocked or when the pass door terminals are not shorted. The LED will blink if there is a momentary obstruction, but is solid when there is a permanent obstruction or a defective safety device.

MODES of Operation:

This controller has six (6) different modes of operation. All operators leave the factory in B2 mode setting. Choose the one that fit your needs by programing the controller as described on page 16 of this manual:

B2 Mode

Momentary press of OPEN or CLOSE buttons.

Delay on Close timer is active. After pressing CLOSE, the door will not move until Delay on Close timer counts out. See page 8 to set or disable the Delay on Close timer. (Factory default = 0 seconds, disabled).

If a fault is generated, momentary presses of CLOSE will not close the door. You can override this by using constant pressure on the CLOSE button until the door is fully closed; if the pressure is released before the door is fully closed it will reverse to full open.

C2 Mode

Momentary press of OPEN, constant pressure required on CLOSE for the door to close. Releasing pressure on the CLOSE button will stop the door.

If you press STOP while holding CLOSE, door will stop.

If you press OPEN while holding CLOSE, door will stop and then reverse to open.

D1 Mode

Constant pressure required on OPEN and CLOSE. Releasing the pressure will cause the door to stop where it is.

If you press STOP while holding OPEN or CLOSE, the door will stop.

E2 Mode

Same as C2 mode with the exception that releasing pressure on CLOSE will cause the door to reverse to open.

T Mode (Timer Mode)

Timer to Close (TTC) can be set for being active at mid-stop and fully open positions or at mid-stop only.

When the door reaches this point the TTC starts to count and the TTC LED blinks. The door will close when the timer ends.

When the TTC is counting, press STOP to cancel the timer and the auto close function. If you have cancelled the timer with the STOP, press OPEN to start the timer again.

If TTC is counting at Mid-Stop, press OPEN to open the door to full open. The TTC will start again if enabled.

If TTC is counting, you can still press CLOSE to close the door.

A fault will restart the TTC if the door is stopped and the TTC had begun. However, a fault after the door has started moving will cause the door to reverse and the TTC will NOT start again when the door gets to mid-stop or full open.

Buttons function like in the B2 mode.

See page 8 to set TTC length and see page 9 to set TTC mode.

TS Mode (Timer Secure Mode)

Same as T Mode except:

Delay on Close is active. After the TTC has expired, the Delay on Close timer, if set, will start and when it expires, the door will close. (Delay on Close factory default = 0 seconds, disabled).

After both the timers have expired and the door is closing, a fault will cause the door to reverse. When the door gets to mid-stop or full open position, the TTC DOES start again followed by the Delay on Close timer.

LX100 DIGITAL CONTROLLER

LX100 Digital controller Overview

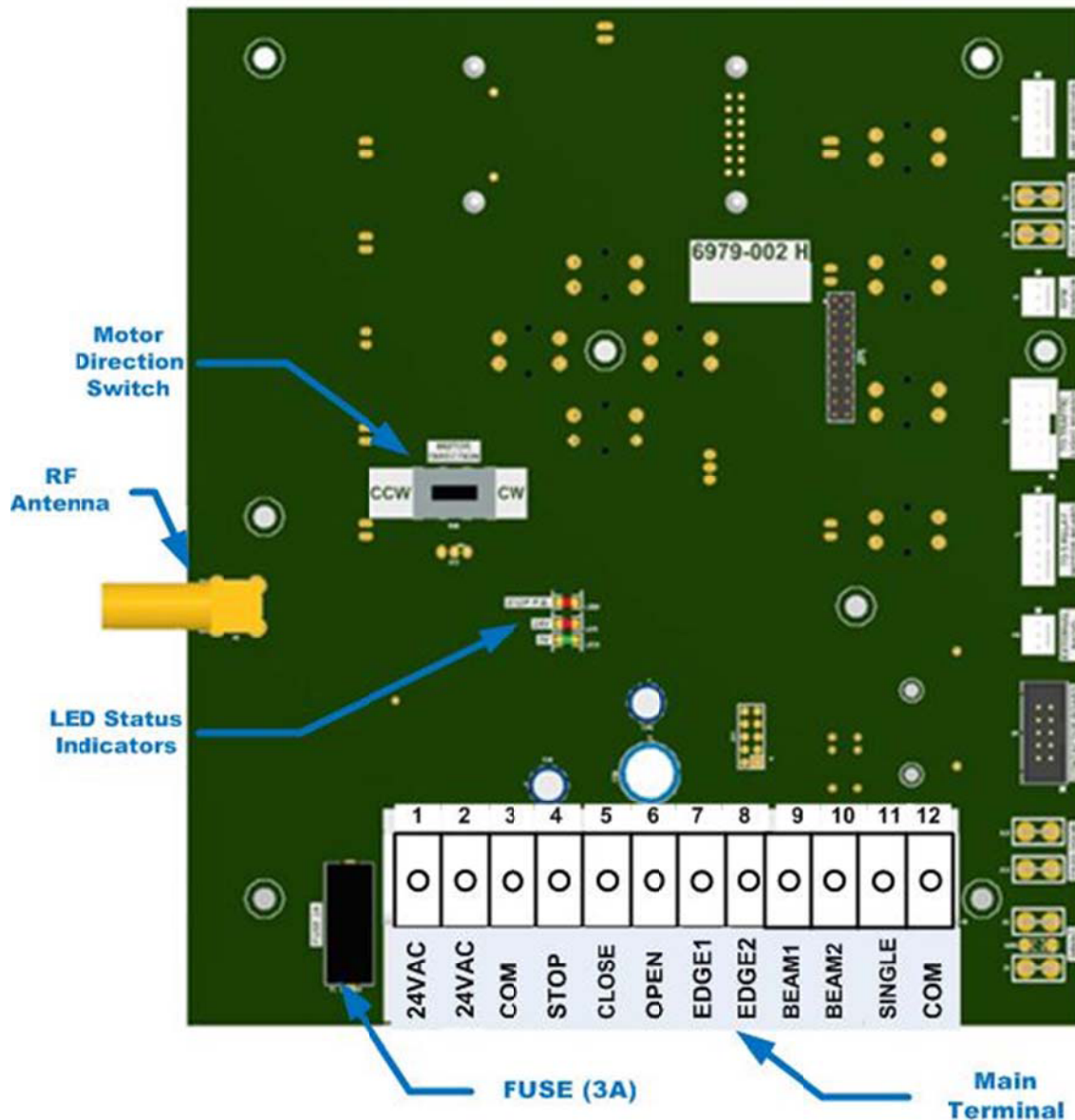

Notes: Before programming the controller, set the operator's open and close limits.

When power is applied to the operator, the following can be observed on the front panel:

The LCD screen displays "NAPOLEON LYNX" with the backlight on. At the same time, all LEDs will flash once each, while scrolling three times. Then the software version of the Logic Board will be flashed using the LEARN, CLOSE, and OPEN LEDs. For example, if the software version is 1.3.3 the following will occur: LEARN LED will flash once, then the CLOSE LED will flash three times, then the OPEN LED will flash three times.

At this point, the OPEN and LEARN buttons are locked out and the LCD backlight goes off. The LCD control buttons are also locked out except for the ENTER button. To unlock the front panel, press ENTER and follow the directions on the LCD screen. After you have pressed the correct button sequence per the directions on the LCD, the display shall show "MENU UNLOCKED" for about 2 seconds, then it will display "OPERATOR MODE". To control the Operator from the front panel, you must depress the BACK button so the display will state "NAPOLEON LYNX". At this point all front panel buttons are functional and the LCD backlight is lit. The Operator will automatically lock out the Front Panel controls after 10 minutes of non-use.

OPEN, STOP and CLOSE buttons are mounted directly on the cover of the operator, making it easy to control the door.

LX100 PROGRAMMING AND OPERATING

PROGRAMMING THE OPERATOR:

From the “NAPOLEON LYNX” screen press ENTER to get to the main menu. Included in the main menu are the Operator Mode, Timer Menu, and Parameters Menu. Use UP or DOWN to select the feature you want and then press ENTER.

Operator Mode is where you can select one of the 6 pre-set operation modes.

The Timer Menu is where you can set up the four timers, Run Timer, Mid-Stop Timer, Timer to Close, and Delay on Close.

The Parameters Menu is where you can select different options, view the cycle counter or reset the operator to factory defaults.

Operator Mode

Once you have selected the Operator Mode and press ENTER, you will be able to press UP or DOWN to scroll to the desired mode of operation: B2, C2, D1, E2, T, or TS.

Press ENTER to implement the selected mode.

Press BACK to cancel and go back to the main menu; the current mode will be the same as before you went into the Operator Mode menu.

Timer Menu

In this menu you can select from Set Run Timer, Mid-Stop Timer, Timer to Close, or Delay on Close. Some of these features are only used in certain modes and can be set, but they may not be used in the selected mode.

Set Run Timer

Make sure that the door is fully closed. If you select “Set Run Timer” and the door is not closed, you will be prompted to close the door; you must then re-enter the Run Mode and press CLOSE.

From the Timer Menu select “Set Run Timer” and press ENTER.

The display will prompt you to press OPEN to start the process or BACK to cancel and maintain the original duration of the timer. You can also press STOP to reset the factory default value.

After you press OPEN, you can let the door open to the limit switch or press STOP at any time. This amount of time, with the addition of 5 seconds, will be saved as the motor run timer.

Set Mid-Stop Timer

Make sure that the door is fully closed. If you select “Mid-Stop Timer” and the door is not closed, you will be prompted to close the door. You must then re-enter the Run Mode and press CLOSE.

From the Timer Menu select “Set Mid-Stop Timer” and press ENTER.

The display will prompt you to press OPEN to start the process or BACK to cancel and maintain the original duration of the timer. You can also press STOP to reset the factory default value.

After you press OPEN you must press STOP at the time when the door is at the desired mid-stop height. This amount of time will be saved as the mid-stop timer.

How Mid-Stop Timer works in different modes:

MODE	FUNCTION
B2	Start at fully closed. Stop at Mid-Stop Press OPEN; go to Full Open Press CLOSE Press STOP below Mid-Stop Press OPEN Door stops at Mid-Stop
C2	Same as in B2 mode; use CP on close.
D1	Once at Mid-Stop, if you go above Mid-Stop, Mid-Stop is cancelled until next Fully Closed. If at Mid-Stop, and you close (not all the way to Fully Closed), OPEN again will stop at Mid-Stop. D1 is constant pressure on OPEN and CLOSE.
E2	Same as in C2 mode.
T	Once at Mid-Stop, if you go above Mid-Stop, Mid-Stop is cancelled until next Fully Closed. If at Mid-Stop, and you close (not all the way to Fully Closed), OPEN again will stop at Mid-Stop.
TS	Same as in T mode.

LX100 PROGRAMMING AND OPERATING

Timer to Close

From the Timer Menu select “Timer to Close” and press ENTER.

Use the UP and DOWN to adjust the time in 1second intervals for the first 10 seconds and then in 5 second intervals.

You can hold these keys to scroll and the display will stop scrolling at the minimum and maximum values.

Press ENTER to select the new value or BACK to keep the original value.

Delay on Close

From the Timer Menu select “Delay on Close” and press ENTER.

Use UP and DOWN to adjust the time in 5-second intervals. You can hold these keys to scroll and the display will stop scrolling at the minimum and maximum values.

Press ENTER to select the new value or press BACK to keep the original value.

Delay on Close factory default = 0 seconds.

LX100 PROGRAMMING AND OPERATING

Parameter Menu

In this menu you can select from Timer to Close Mode, Delay on Reverse, Single Button Mode, Cycle Counter, and Reset All Parameters.

Timer to Close Mode

From the Parameter Menu, select “Timer to Close Mode” and press ENTER.

Use UP and DOWN keys to select “Mid-Stop & Full Open” or “Mid-Stop Only.”

Press ENTER to select the new option or press BACK to cancel the operation and keep the original choice.

Delay on Reverse Time

This is the time it takes for the motor to slow down and engage in the opposite direction once a safety reverse is detected or OPEN is pressed, when the door is closing.

From the Parameter Menu, select “Delay on Reverse” and hit ENTER.

Use UP and DOWN keys to adjust the time in 0.1second intervals. You may use these keys to scroll and the display will stop scrolling at the minimum and maximum limits, 1 and 1.9 seconds respectively.

Press ENTER to select the new option or press BACK to cancel.

Single Button Mode

From the Parameter Menu select “Single Button Mode” and press ENTER.

Use UP and DOWN to select “Normal Sequence” or “Refresh Timer.” Normal Sequence is used for the open-close-stop-reverse operation. Refresh can be used in T or TS modes to reset TTC while in the open position.

Press ENTER to select the new option or press BACK to cancel.

MODE	P0 (Start)	P1 (Push 1)	P2	P3	P4
B2 – Norm	FC ¹	OPEN	STOP	CLOSE	REV(OPEN) ²
B2 – Refresh	Same as B2 – Norm				
C2 – Norm	FC	OPEN	STOP	CP CLOSE	RELEASE STOP
C2 – Refresh	Same as C2 – Norm				
D1	There is no single button in D1 mode.				
E2 – Norm	FC	OPEN	STOP	CP CLOSE	RELEASE REV
E2 – Refresh	Same as E2 – Norm				
T – Norm	FC	OPEN	STOP	CLOSE(or TTC) ³	REV(OPEN)
T – Refresh	FC	OPEN	TTC Refresh ⁴	TTC Refresh	After TTC finish, REV(OPEN) ⁵
TS – Norm	FC	OPEN	STOP	CLOSE(or TTC)	REV(OPEN)
TS – Refresh	FC	OPEN	TTC Refresh	TTC Refresh	After TTC finish, REV(OPEN)

1. FC – Fully Closed
2. Reverse to Open position
3. Door will close if you press the single button or wait for the timer to end
4. Restart the Timer to Close
5. After the TTC has ended and the door is closing, if button is pressed the door will Reverse to Open position

Internal Cycle Counter

From the Parameter Menu select “Cycle Counter” and press ENTER.
Press ENTER again when display says “Counter Show Val.”
The cycle counter will be displayed and cannot be erased because it is used for maintenance.
Press BACK when done.

Reset All Parameters

From the Parameter Menu select “Reset All Parameters” and press ENTER.
Press ENTER again.
You will be prompted to hold the ENTER key for 10 seconds. The display will count down to zero. This will restore the operator to factory defaults except for the internal cycle counter. If you let go before the 10 seconds are up, the parameters are not reset.
Press BACK when done.

RADIO CONTROLS

Three Button Open, Close, Stop

These buttons are mapped to the same functions as the wired control.
CLOSE will not work in modes that require constant pressure: C2, D1, E2.

Single Button

This function is mapped to the same functions as the Single Push Button.
The CLOSE function does not work in C2 or E2. None of the functions work in D1.

Three Button, Three Door

Each button works independently to control three different doors.
The function of each button is mapped to the same functions as the Single Push Button.
The CLOSE function does not work in C2 or E2. None of the functions work in D1.

LX100 FIELD WIRING DIAGRAM

LX-100 Wiring Connections

****Stop and Com must be jumpered when a 3-Button Wall Station is Present**



Rev.
09/11/15

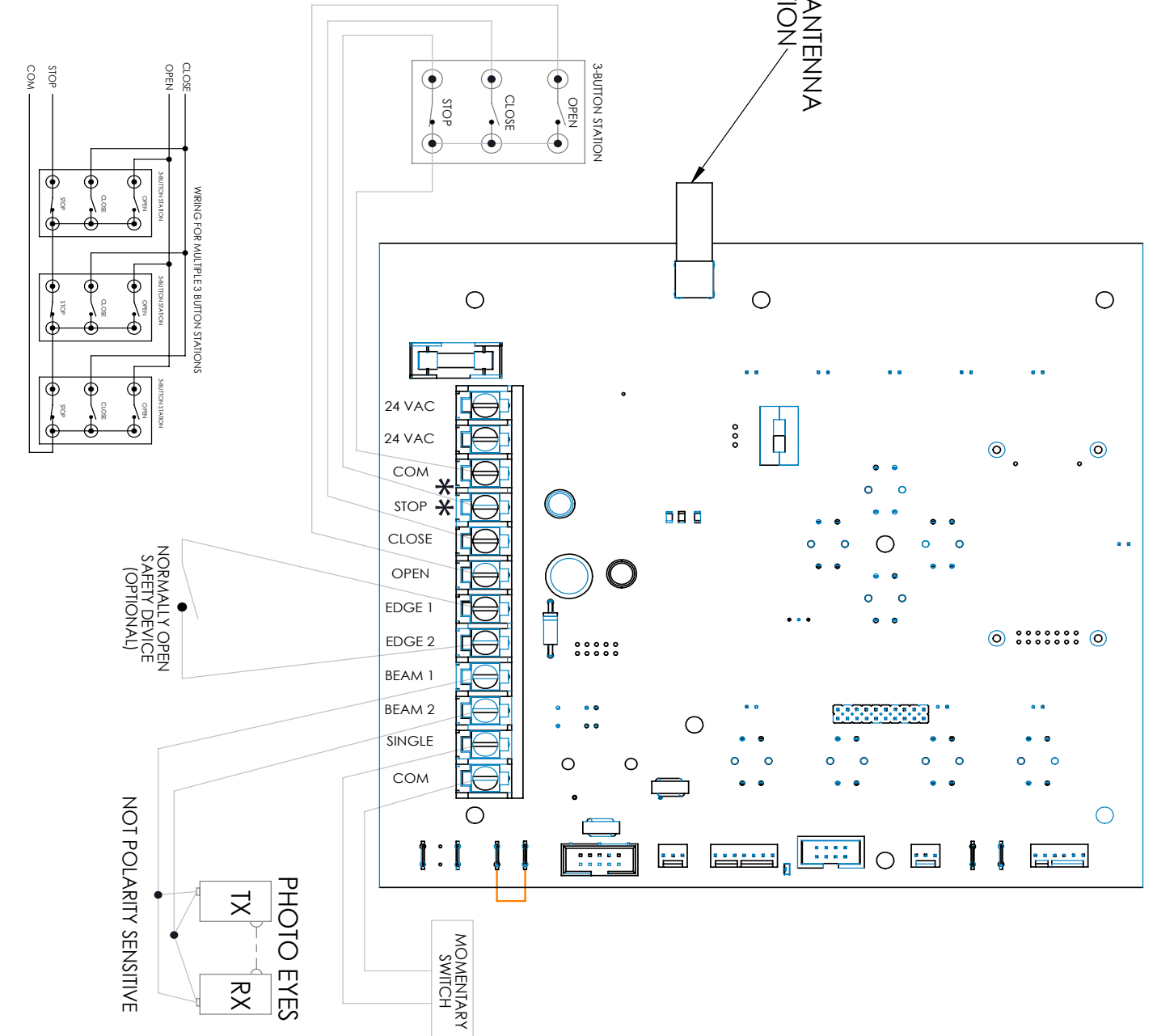
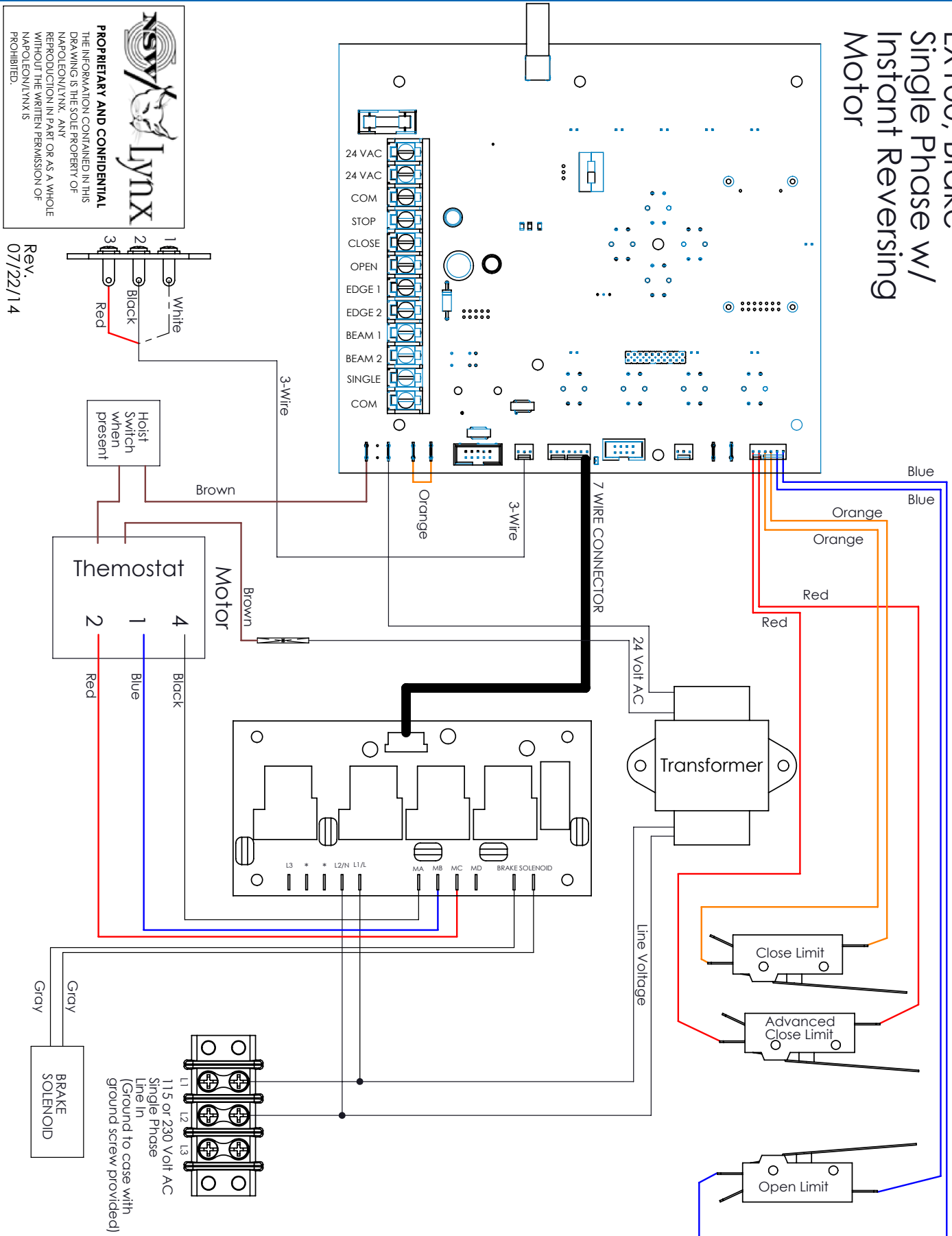

FIGURE 10

MCJ, MCJH, MCJB, MCJBH

WIRING DIAGRAM

LX100, Brake
Single Phase w/
Instant Reversing
Motor



NSV/LYNX
PROPRIETARY AND CONFIDENTIAL
 THE INFORMATION CONTAINED IN THIS DRAWING IS THE SOLE PROPERTY OF NAPOLEON/LYNX. ANY REPRODUCTION IN PART OR AS A WHOLE WITHOUT THE WRITTEN PERMISSION OF NAPOLEON/LYNX IS PROHIBITED.

Rev. 07/22/14
 1 White
 2 Black
 3 Red

WIRING DIAGRAM

LX100, Brake
Single Phase w/
1+ HP Motor
Cap Start

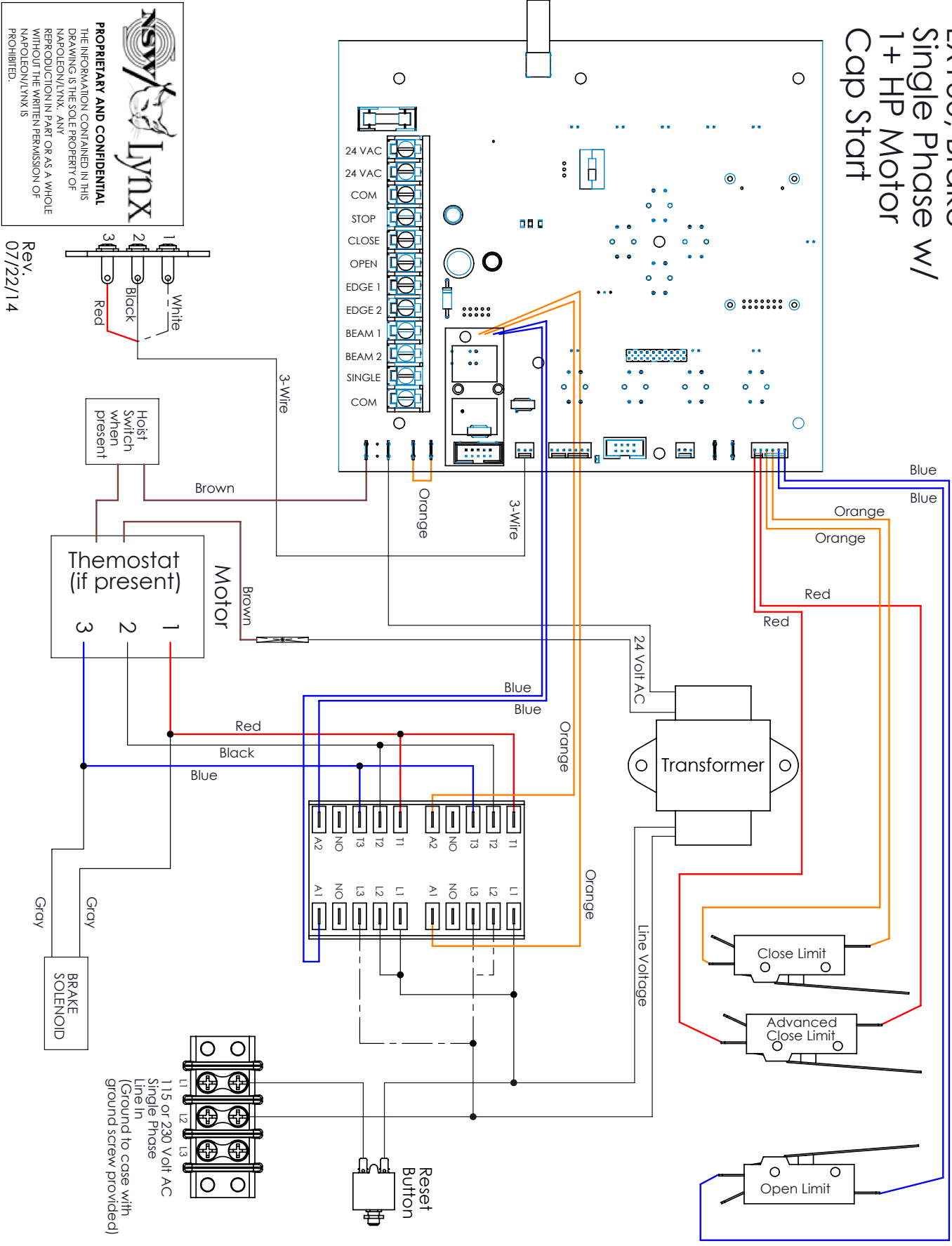

NSV/ Lynx
PROPRIETARY AND CONFIDENTIAL
 THE INFORMATION CONTAINED IN THIS DRAWING IS THE SOLE PROPERTY OF NAPOLEON/LYNX. ANY REPRODUCTION IN PART OR AS A WHOLE WITHOUT THE WRITTEN PERMISSION OF NAPOLEON/LYNX IS PROHIBITED.

Rev. 07/22/14
 1 White
 2 Black
 3 Red

WIRING DIAGRAM

LX100, Brake
Three Phase
460 Volt

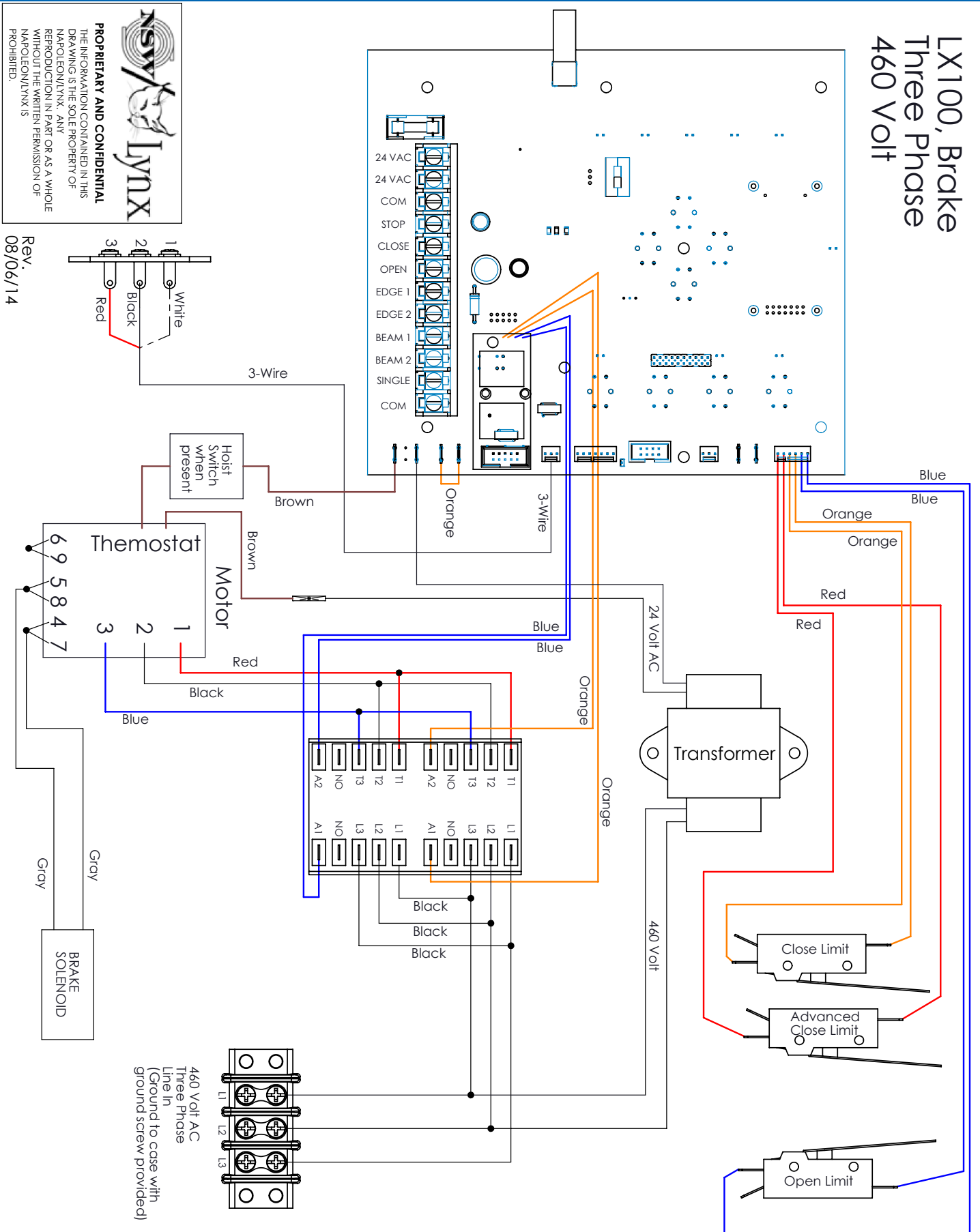

NSV/lynx
PROPRIETARY AND CONFIDENTIAL
 THE INFORMATION CONTAINED IN THIS DRAWING IS THE SOLE PROPERTY OF NAPOLEON/LYNX. ANY REPRODUCTION IN PART OR AS A WHOLE WITHOUT THE WRITTEN PERMISSION OF NAPOLEON/LYNX IS PROHIBITED.

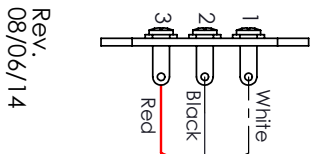

Rev. 08/06/14

WIRING DIAGRAM

LX100, Brake
Three Phase
230 Volt w/
Overload Protection

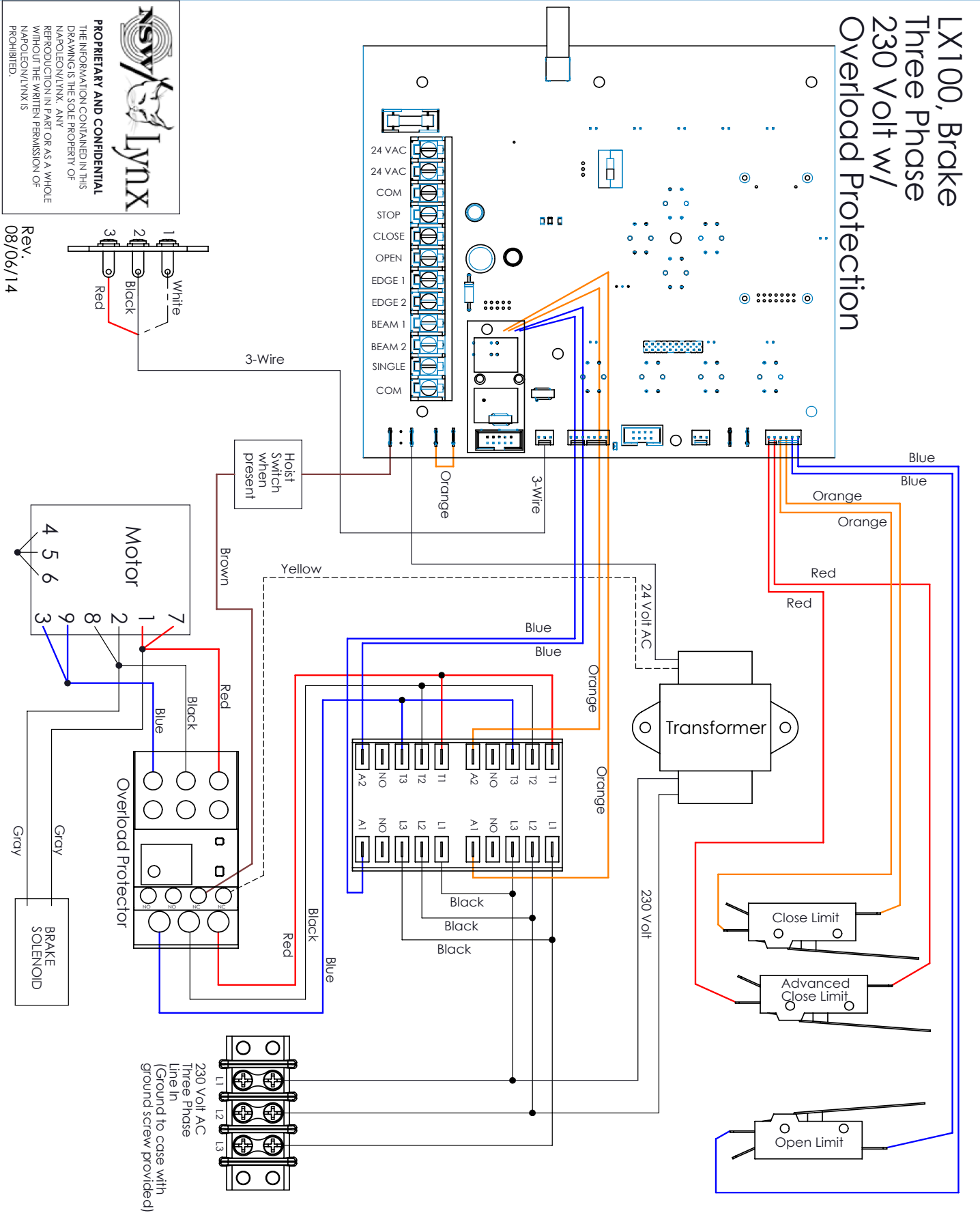

WIRING DIAGRAM

LX100, Brake
Three Phase
460 Volt w/
Overload Protection

NSV/LYNX
PROPRIETARY AND CONFIDENTIAL
 THE INFORMATION CONTAINED IN THIS
 DRAWING IS THE SOLE PROPERTY OF
 NAPOLEON/LYNX. ANY
 REPRODUCTION IN PART OR AS A WHOLE
 WITHOUT THE WRITTEN PERMISSION OF
 NAPOLEON/LYNX IS
 PROHIBITED.

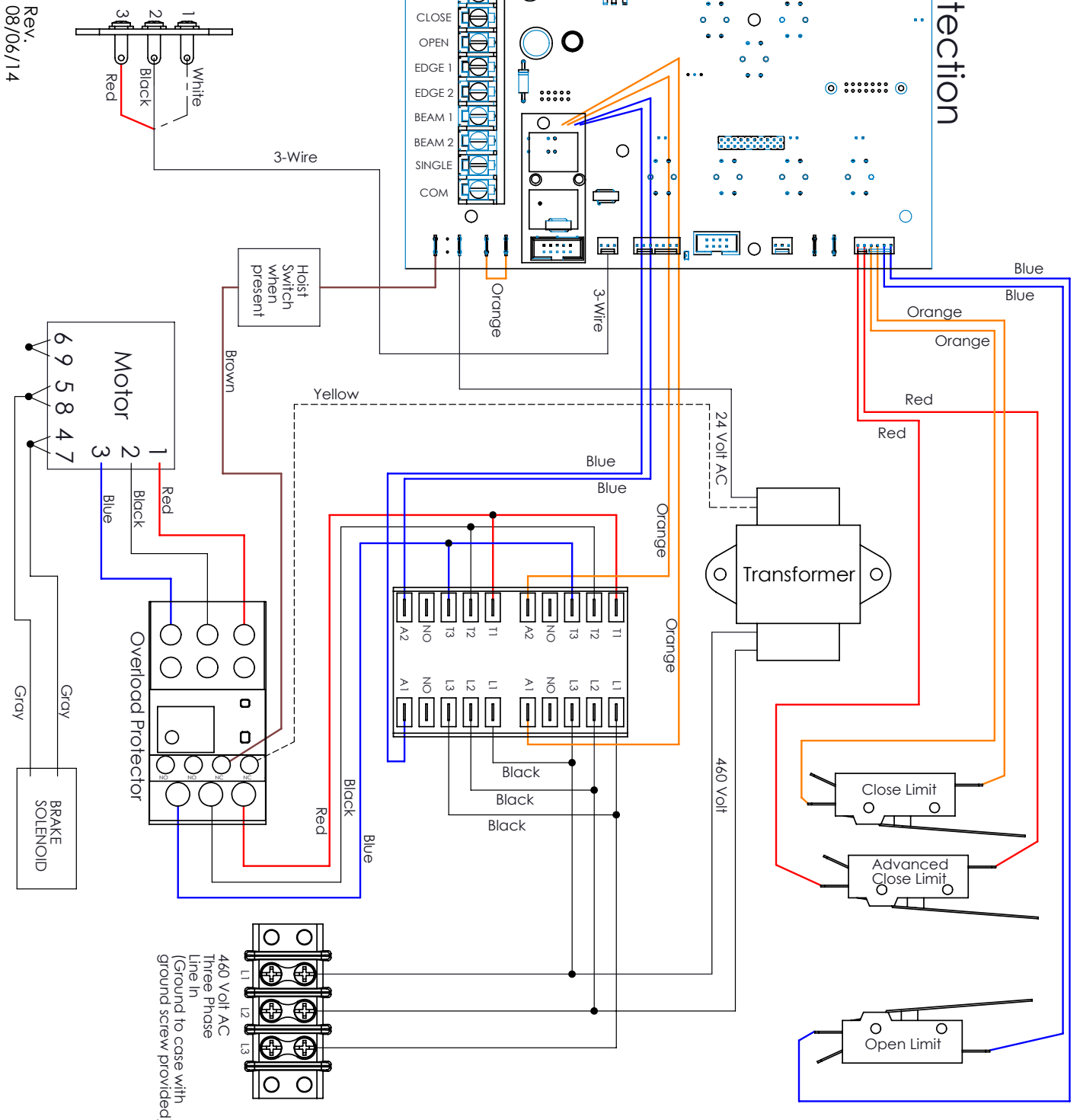

Rev.
 08/06/14

WIRING DIAGRAM

LX100, Brake
Single Phase w/
Cap Start, 115V Motor

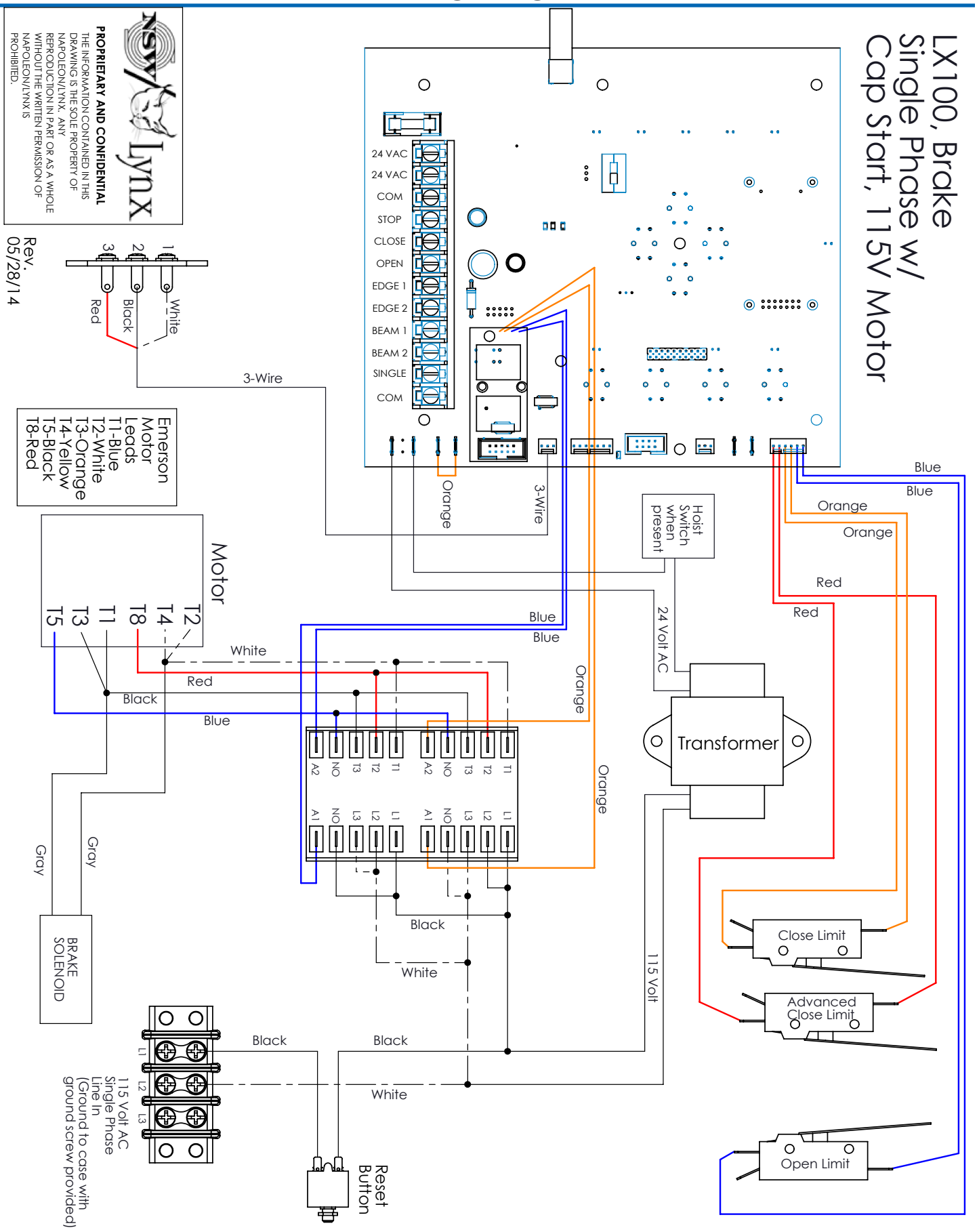

nsy/lynx
PROPRIETARY AND CONFIDENTIAL
 THE INFORMATION CONTAINED IN THIS DRAWING IS THE SOLE PROPERTY OF NAPOLEON/lynx. ANY REPRODUCTION IN PART OR AS A WHOLE WITHOUT THE WRITTEN PERMISSION OF NAPOLEON/lynx IS PROHIBITED.

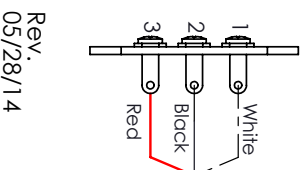

Emerson Motor Leads
 T1-Blue
 T2-White
 T3-Orange
 T4-Yellow
 T5-Black
 T8-Red

WIRING DIAGRAM

LX100, Brake
Single Phase w/
Cap Start, 230V Motor

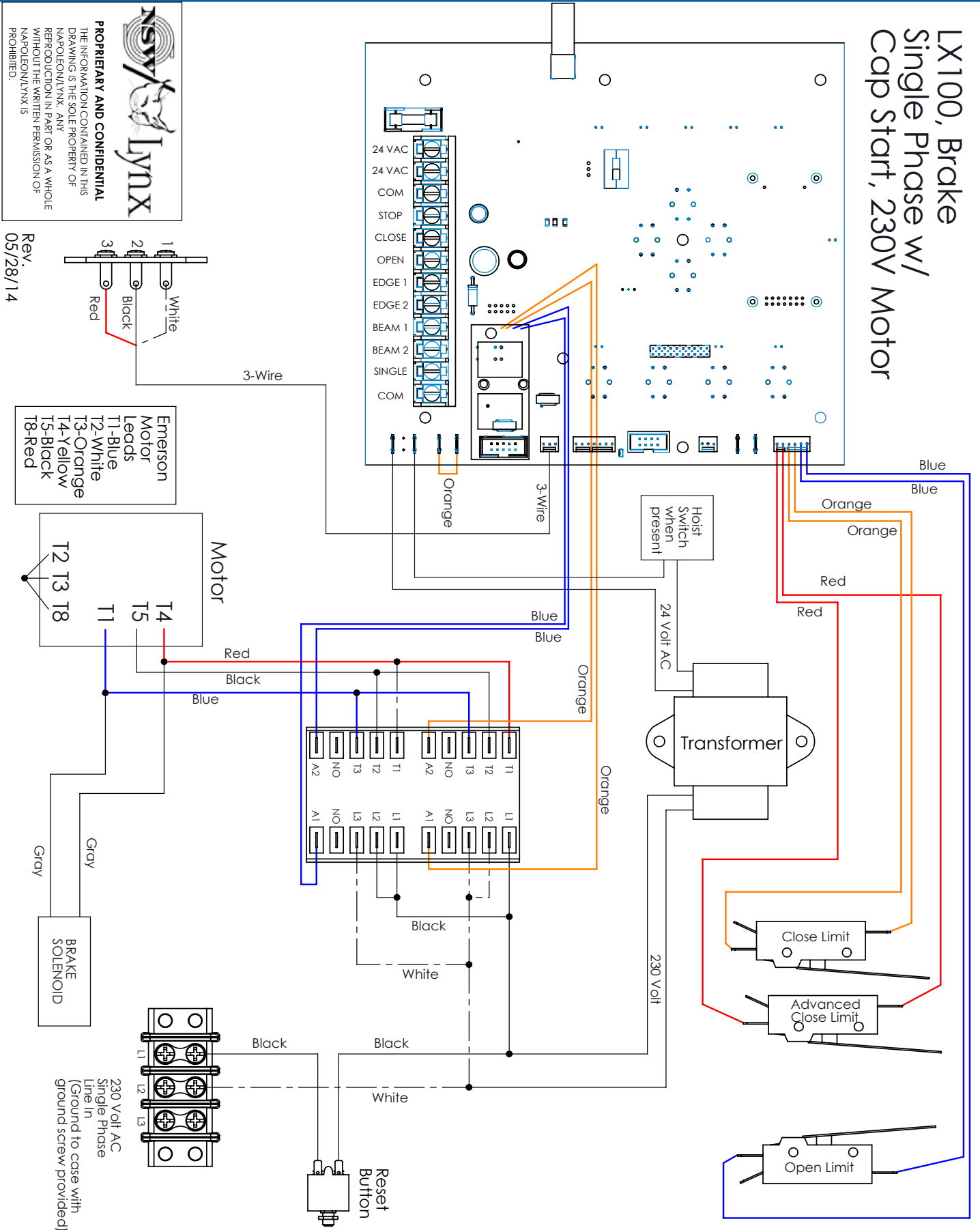

nsy/lynx
PROPRIETARY AND CONFIDENTIAL
 THE INFORMATION CONTAINED IN THIS DRAWING IS THE SOLE PROPERTY OF NAPOLEON/LYNX. ANY REPRODUCTION IN PART OR AS A WHOLE WITHOUT THE WRITTEN PERMISSION OF NAPOLEON/LYNX IS PROHIBITED.

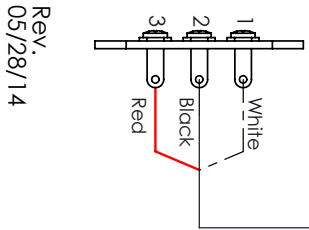

Emerson Motor Leads

- T1-Blue
- T2-White
- T3-Orange
- T4-yellow
- T5-Black
- T8-Red

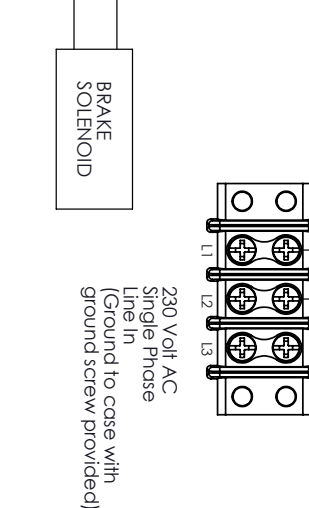
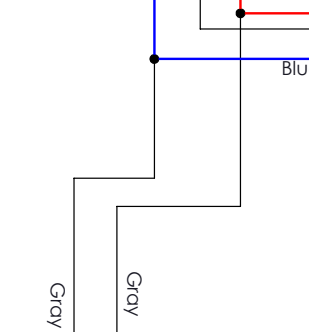
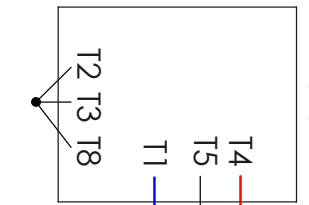

Rev. 05/28/14

WIRING DIAGRAM

LX100, Brake
Single Phase w/
Cap Start
Motor - LX225

NSV/lynx
LYNX
PROPRIETARY AND CONFIDENTIAL
THE INFORMATION CONTAINED IN THIS
DRAWING IS THE SOLE PROPERTY OF
NAPOLEON/LYNX. ANY
REPRODUCTION IN PART OR AS A WHOLE
WITHOUT THE WRITTEN PERMISSION OF
NAPOLEON/LYNX IS
PROHIBITED.

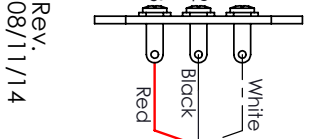

Rev.
08/11/14

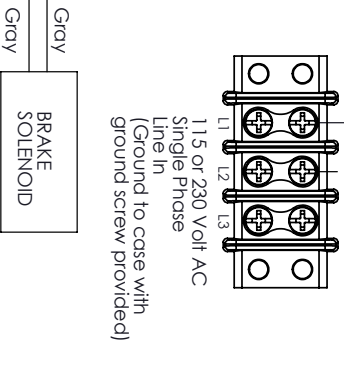
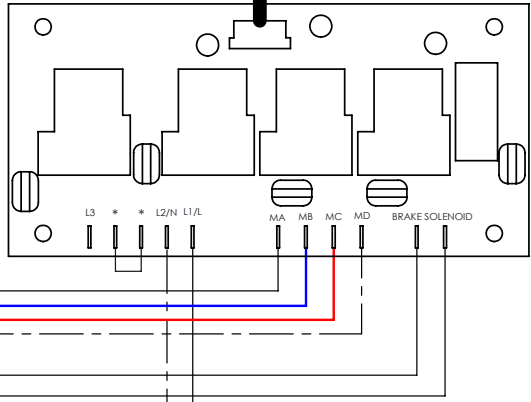
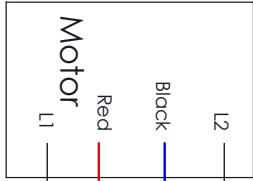
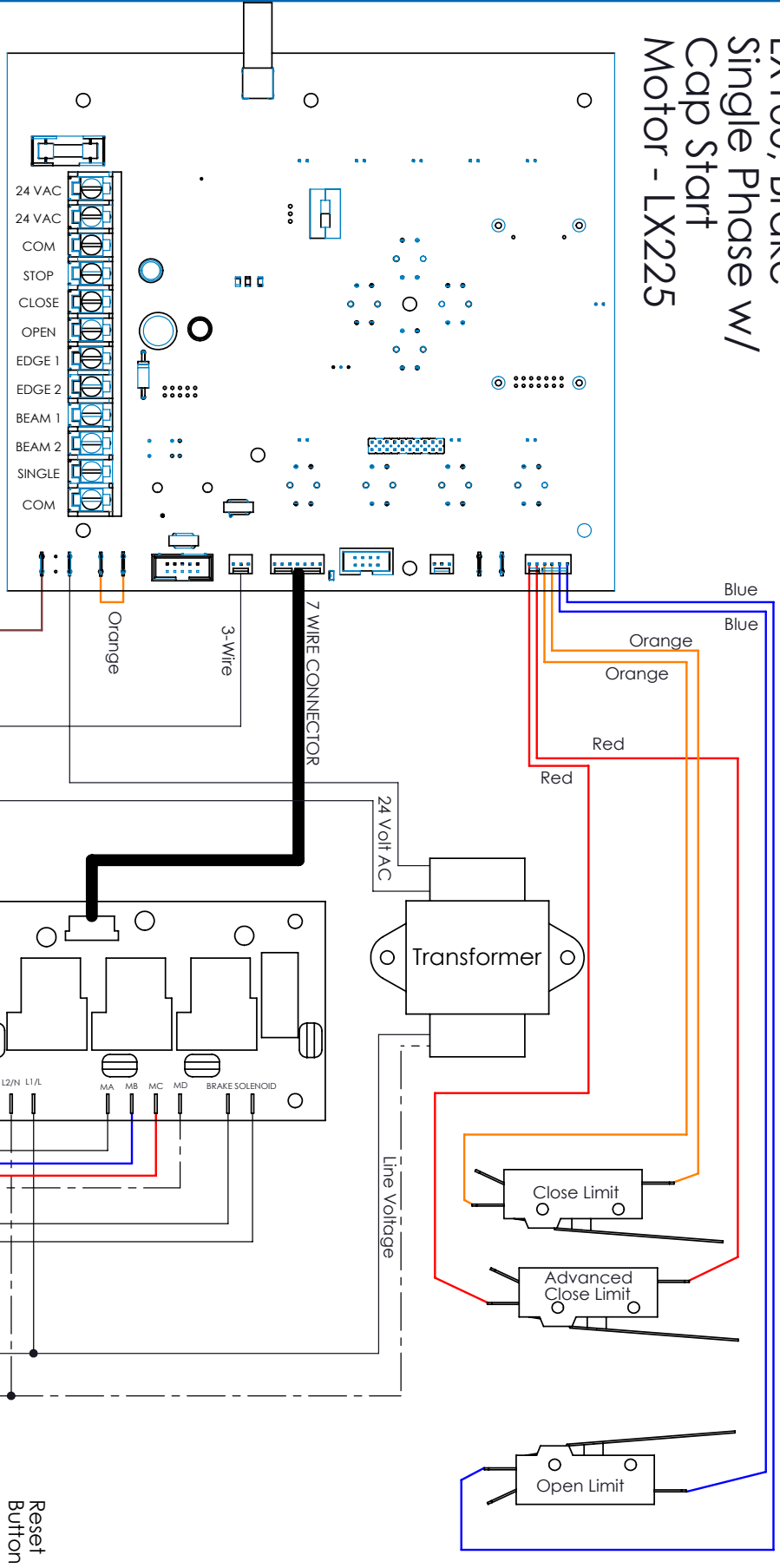

SHOP DRAWING

