

INDUSTRIAL DUTY TROLLEY

MC3-WASHDOWN

Industrial Duty Trolley Washdown Operators are engineered for standard lift doors and are designed for continuous duty operation.

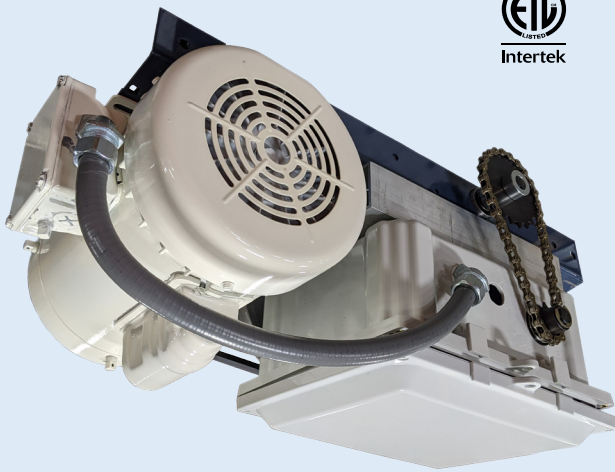

MC3-WD MODEL SHOWN

FEATURES

- 1/2 HP, 3/4 HP, and 1 HP - 115V/230V-1 Phase Motor
- 208/230/460/575V-3 Phase Motor
- 3 Button station (NEMA 1)
- 1650 RPM, high starting torque motor with overload protection
- LX 100 BOARD Standard Features (See Accessories cut sheet for more details)
- B2 Mode, C2 Mode, D1 Mode, E2 Mode, T Mode, TS Mode
- On board, Open, Close, & Stop for ease of setting limits
- Photo-eyes included (Waterproof)
- Pre-wired to accept sensing devices
- 24 Volt accessory power
- On board (372 MHz) receiver capable of programming up to 20 transmitters
- External receiver connection
- Ground level disconnect for manual operation
- NEMA 4x Electrical enclosure
- Adjustable friction clutch
- Primary Drive: Heavy Duty 4L V-Belt - #65 Drive Chain
- Door speed: Approx. 10" per second
- Doors up to 24 feet high
- Warranty
 - 2 years on parts and motor

MC3 Series Options

	OPTIONAL
	#41
	
	DRIVE
MC3-WD	
MC3-H-WD	X

MC3

SERIES

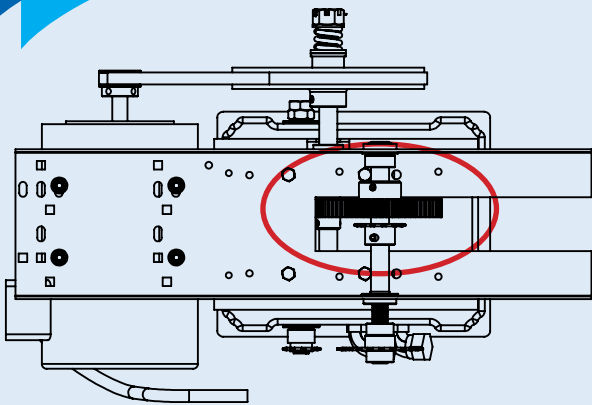
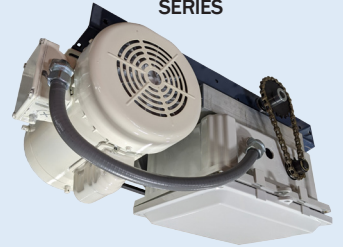

Manual Operation Release
Trolley automatically reconnects or can be manually reconnected with ease.

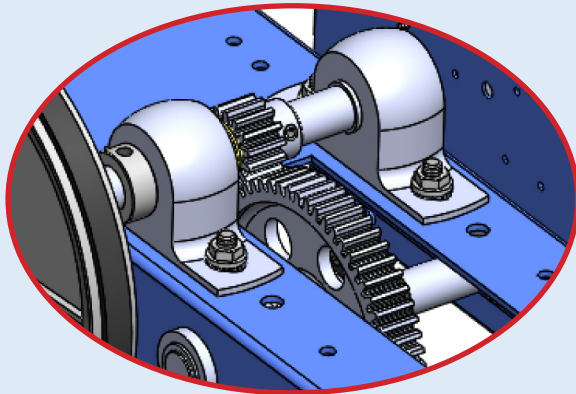
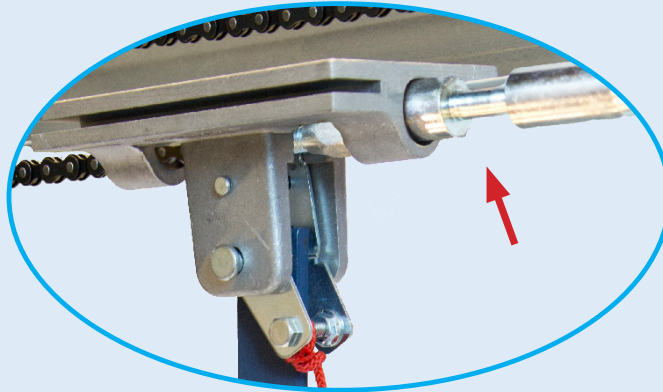

GEAR REDUCTION
Improved motion control and stability.

SHOP DIAGRAMS

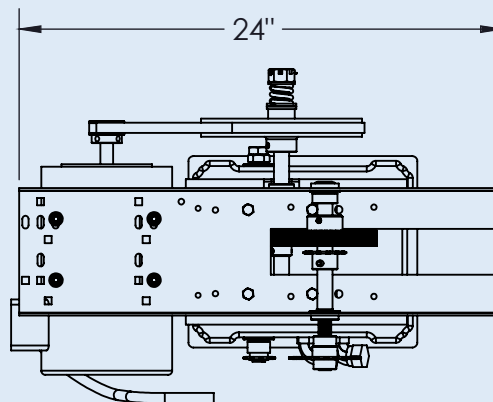
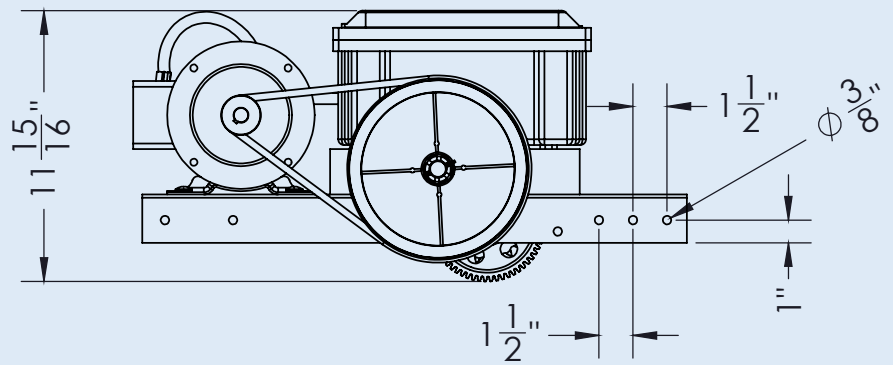

Intertek



PROUDLY BUILT IN NORTH AMERICA

READY TO ORDER?

Please have the following information available:

- Optional solenoid brake
- Height of the door
- Area of the door
- Number of transmitters needed

800-233-3599
ARIZONA

101 N. 57th Ave.
Phoenix, AZ
85043

800-234-5969
NEW JERSEY

613 Industrial Rd.
Carlstadt, NJ
07072

800-338-5399
OHIO

111 Weires Dr.
Archbold, OH
43502

888-589-5969
QUEBEC

175 Upper Eddison Ave.
St. Lambert, QC
J4R 2R3

888-839-5969
ONTARIO

6311 Vipond Dr.
Mississauga, ON
L5T 1T7